

Operating instructions

Explosion protection slide valve RSV

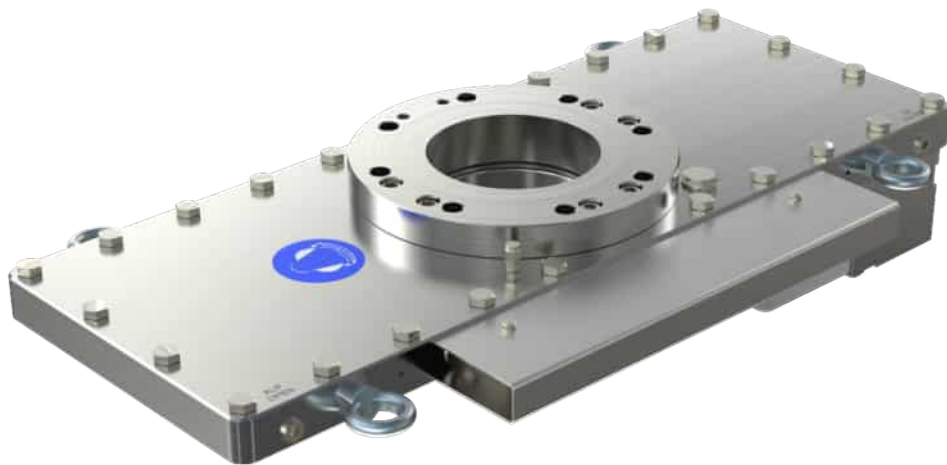

The original operating instructions were written in German

Index: g, 14/04/2021

rico 
CERTIFIED SAFETY

Read the instructions prior to performing any task!

RICO Sicherheitstechnik AG
St. Gallerstrasse 26
CH-9100 Herisau
Telephone: +41 (0)71 351 10 51
Email: info@rico.ch
Internet: <http://www.rico.ch>

MB0008DE, 7, en_GB

Table of contents

1	General information	7
1.1	Manufacturer.....	7
1.2	Purpose of the operating instructions.....	7
1.3	Target group.....	7
1.4	Scope of application and use of the operating instructions.....	7
1.5	Warranty and guarantee conditions.....	8
1.6	Storage.....	8
1.7	Copyright notice.....	9
1.8	Typographical conventions.....	9
1.9	Definition of terms.....	9
2	General safety information	10
2.1	Manufacturer's area of responsibility.....	10
2.2	Operator's area of responsibility.....	10
2.2.1	Training, expertise.....	10
2.2.2	Protective equipment.....	10
2.2.3	Duty of maintenance and due diligence.....	10
2.3	Intended use.....	11
2.4	Types of safety information.....	12
2.4.1	Symbols used.....	12
2.4.2	User information.....	14
2.5	Special dangers.....	14
2.6	Combination with other products.....	15
3	Product description of RSV-D	16
3.1	Functional principle.....	16
3.2	Pressure shock-resistant design.....	16
3.3	ATEX zones.....	17
3.4	Explosion pressure and process temperature.....	17
3.5	Media.....	17
3.6	Technical data.....	17
3.6.1	Technical data sheet & installation guideline.....	17
3.6.2	Assembly diagram & parts list.....	18
3.6.3	Name plate.....	18
3.6.4	Gas generator.....	18
3.6.5	Switches.....	18
4	Product description of RSV-G	19
4.1	Functional principle.....	19
4.2	Pressure shock-resistant design.....	19
4.3	ATEX zones.....	20
4.4	Explosion pressure and process temperature.....	20
4.5	Media.....	20
4.6	Technical data.....	20
4.6.1	Technical data sheet & installation guideline.....	20

4.6.2	Assembly diagram & parts list.....	21
4.6.3	Name plate.....	21
4.6.4	Gas generator.....	21
4.6.5	Switches.....	21
5	Product description of RSV-P.....	22
5.1	Functional principle.....	22
5.2	Pressure shock-resistant design.....	22
5.3	ATEX zones.....	23
5.4	Explosion pressure and process temperature.....	23
5.5	Media.....	23
5.6	Technical data.....	23
5.6.1	Technical data sheet & installation guideline.....	23
5.6.2	Assembly diagram & parts list.....	24
5.6.3	Name plate.....	24
5.6.4	Gas generator.....	24
5.6.5	Switches.....	24
6	Assembly of RSV-D/RSV-G and RSV-P.....	25
6.1	Assembly advice.....	25
6.2	Direction of explosion.....	25
6.3	Installation position.....	26
6.4	Tightening torques.....	26
6.5	Electrical connections.....	27
6.6	Compressed air.....	27
6.7	Welding work.....	27
7	Commissioning RSV-D.....	28
7.1	Commissioning	28
7.2	Functionality test.....	28
8	Maintenance of RSV-D.....	31
8.1	Maintenance.....	31
8.1.1	Test process after an explosion/fire.....	32
8.2	Recurring maintenance.....	33
8.2.1	Functionality test.....	33
8.2.2	Visual check and wear monitoring.....	36
9	Inspection of RSV-D.....	37
9.1	Gas generator replacement.....	37
9.2	Replacing the gas generator holder.....	41
9.3	Replace the active seals.....	43
9.4	Replacing the seals on the housing and gas generator holder.....	44
9.5	Replacing the locking screw seal.....	46
9.6	Replacing the slide blade.....	47
10	Commissioning RSV-G.....	49
10.1	Commissioning.....	49
10.1.1	Functionality test RSV-G/RSV-P.....	49

10.2	Commissioning for the inliner version.....	52
10.2.1	Functionality test RSV-G/RSV-P for the inliner version.....	53
11	Maintenance of RSV-G.....	55
11.1	Maintenance.....	55
11.1.1	Test process after an explosion/fire.....	56
11.2	Recurring maintenance.....	56
11.2.1	Functionality test RSV-G/RSV-P.....	56
11.2.2	Functionality test RSV-G/RSV-P for the inliner version.....	59
11.2.3	Visual check and wear monitoring.....	61
11.2.4	Visual check and wear monitoring for the inliner version.....	62
12	Inspection of RSV-G.....	64
12.1	Gas generator replacement.....	64
12.2	Replacing the gas generator holder.....	68
12.3	Replacing the FEP-O-seals.....	70
12.3.1	Replacing the inliner seal.....	71
12.4	Replacing the seals on the housing and gas generator holder.....	74
12.5	Replacing the locking screw seal.....	76
12.6	Replacing the slide blade.....	77
13	Commissioning RSV-P.....	79
13.1	Commissioning	79
13.1.1	Functionality test RSV-G/RSV-P.....	79
13.2	Commissioning for the inliner version.....	82
13.2.1	Functionality test RSV-G/RSV-P for the inliner version.....	83
14	Maintenance of RSV-P.....	85
14.1	Maintenance.....	85
14.1.1	Test process after an explosion/fire.....	86
14.2	Recurring maintenance.....	86
14.2.1	Functionality test RSV-G/RSV-P.....	86
14.2.2	Functionality test RSV-G/RSV-P for the inliner version.....	89
14.2.3	Visual check and wear monitoring.....	91
14.2.4	Visual check and wear monitoring for the inliner version.....	92
15	Inspection of RSV-P.....	94
15.1	Gas generator replacement.....	94
15.2	Replacing the gas generator holder.....	98
15.3	Replacing the FEP-O-seals.....	100
15.3.1	Replacing the inliner seal.....	101
15.4	Replacing the seals on the housing and gas generator holder.....	105
15.5	Replacing the seal for RSV-P.....	107

Table of contents

15.6	Replacing the locking screw seal.....	108
15.7	Replacing the slide blade.....	108
16	Disposing of RSV-D / RSV-G and RSV-P.....	111
16.1	Disposal.....	111
16.2	Gas generator.....	111
17	Maintenance book.....	112
18	Index.....	120

1 General information

1.1 Manufacturer

RICO Sicherheitstechnik AG

St. Gallerstrasse 26

CH-9100 Herisau

Tel.: +41 (0)71 351 10 51

info@rico.ch

www.rico.ch

1.2 Purpose of the operating instructions

The purpose of the operating instructions is to provide the personnel employed by the operator with the necessary knowledge to safely handle the product. Safe handling includes (in addition to operation) all the phases of the product's life cycle described in these operating instructions, such as commissioning, set-up, use, cleaning, maintenance, decommissioning, transport, disposal etc.

1.3 Target group

The target group for these operating instructions are the operator and the certified service personnel.



Assembly, operation, maintenance and repair of the product may only be carried out by certified, specialist personnel.

Specialist personnel can only be certified by RICO Sicherheitstechnik AG or service partners authorised by RICO Sicherheitstechnik AG and certification must be renewed every two years.

1.4 Scope of application and use of the operating instructions

These operating instructions form an integral part of the product. Knowledge of the information contained therein is indispensable for safe and problem-free handling. The manufacturer waives any liability for damage to materials or injury to persons resulting from a lack of knowledge of, or non-adherence to, the operating instructions.

General information

Storage



The operator is responsible for ensuring that it and all persons authorised for the activity in question on the product have read and understood the operating instructions in their entirety before commissioning.



Any questions or unclear points should be raised with the manufacturer or your sales representative.

1.5 Warranty and guarantee conditions

The product is designed according to state-of-the-art knowledge, constructed from high-quality materials and carefully checked and tested in the manufacturer's plant before delivery. However, should you identify any faults or damage during commissioning, operation, cleaning, maintenance, decommissioning or storage, please inform the manufacturer of these in writing immediately. The manufacturer will provide a replacement for the faulty or defective parts in the delivered equipment as part of the General Terms and Conditions of Sale and Delivery.

No warranty applies to damage resulting from:

- A lack of knowledge of, or non-adherence to, the operating instructions
- Use contrary to the intended use
- Inadequate maintenance
- Use of unsuitable replacement parts (only original replacement parts may be used)
- Use of unsuitable accessories
- Work performed by uncertified personnel



For warranty claims to be accepted, the damaged parts must be returned to the manufacturer together with a description of the defect and the serial number.

Material covered by the warranty will be replaced as quickly as possible ex works.

1.6 Storage

The operator is always responsible for the storage location of the operating instructions. The operating instructions must be available at all times to all persons employed by the operator in case they are required.

The operating instructions must be stored carefully for the entire 15 years of the product's service life, and if required, updated with subsequent information from the manufacturer.

If the product is sold or decommissioned, the operating instructions must be handed over to the new operator or disposal company.

Lost operating instructions, drawings, parts lists and the technical data sheets can be re-ordered from the manufacturer by stating the fabrication number.

1.7 Copyright notice

© 2015 RICO Sicherheitstechnik AG

All rights reserved. Subject to changes and further developments as a result of technological progress, and subject to printing errors.

The copyrights to the product, documentation and other data remain with the manufacturer or author. Any transfer to third parties, reproduction or other dissemination, even in part, without the express consent of the manufacturer, is prohibited. The above does not apply to the creation of document copies for personal use and the instruction of personnel employed by the operator.

1.8 Typographical conventions

Bold mark-up

Important information is marked in **bold** in order to draw the target group's attention.

1.9 Definition of terms

The explosion protection components, VENTEX®, explosion protection slide valve RSV, REDEX® Slide or REDEX® Flap are referred to as "product", "valve", "slide valve" or "flap" in these operating instructions.

General safety information

Operator's area of responsibility > Duty of maintenance and due diligence

2 General safety information



Handling-related safety information provides warnings of risks and risk points associated with handling and are visible immediately **before the step in question**.

2.1 Manufacturer's area of responsibility

The manufacturer is responsible for the flawless delivery of the product from a technical safety perspective, including the operating instructions.

2.2 Operator's area of responsibility



Assembly, operation, maintenance and repair of the product may only be carried out by certified, specialist personnel.



The operator and the certified specialist personnel must have fully read and understood the operating instructions.

2.2.1 Training, expertise

The operator ensures that all activities carried out on the product are performed by certified specialist personnel only.

2.2.2 Protective equipment

The operator ensures the provision of personal protective equipment appropriate to the situation for its employees (e.g. gloves, respiratory protection, hearing protection etc.).

2.2.3 Duty of maintenance and due diligence

The operator ensures that the product is maintained and operated in a technically perfect condition. The operator shall carry out the stipulated checks and the required maintenance work and shall authorise/organise all service and repair work, which can only be carried out by a certified specialist.



Maintenance documentation

All activities carried out on the explosion protection slide valve should be documented or entered at www.service.rico.ch for traceability purposes.

2.3 Intended use

The slide valve is built into pipelines. The slide valve must not be fitted to the end of a pipe. There must be another section of pipe after the slide valve (risk of injury due to the possibility of reaching in). The intended use must be ensured. The manufacturer provides no guarantee in the event of unsuitable, incorrect or improper use, faulty assembly or repairs, failure to comply with quality assurance measures, failure to observe the instructions for use or maintenance on the part of the customer or third parties, or natural wear and tear, unsuitable operating materials, replacement materials, replacement parts from third parties, defective media connections, or chemical, electrochemical, electrical or thermal influences, unless the manufacturer is responsible for the above. The buyer must always check that the sealing material is compatible with the medium, the application and the ambient temperature. The RICO order confirmation is authoritative in the event of doubt.

The RSV-D is designed and built for use in pipelines through which a **dust/air mixture** flows and in which a vacuum is present.

The RSV-G or RSV-P is designed and built for use in pipelines through which **dust/gas and hybrid mixtures** flow and in which a vacuum and a maximum excess pressure of < 0.5 bar is present.

Pressures of up to 6 bar are permissible if the inliner is used, however not in combination with pneumatic pumping (abrasive wear of the inliner). This does not include selective pressurisation or a high-pressure cleaner.



Other applications are only permissible after clarification and with the express approval of the manufacturer.

The following must be observed when the RSV is used with a gas/air and dust mixture:

- The mechanical closing process must never be impeded. Special attention should be paid to impairment due to caking as a result of condensate combined with dust. The air must therefore be dry.
- In general, the slide valve must not be installed in pipelines in which fluids flow through the pipeline. If cleaning fluids are used, the "inliner" variant must be ordered and used. This variant cannot be retrofitted.

General safety information

Types of safety information > Symbols used

2.4 Types of safety information



DANGER!

Designates an **imminent danger**. If this danger is not avoided, **it will result in death or serious, irreversible injury**.



WARNING!

Designates a **potentially dangerous situation**. If this dangerous situation is not avoided, **it may result in death or serious, irreversible injury**.



CAUTION!

Designates a **potentially dangerous situation**. If this dangerous situation is not avoided, **it may result in minor or minimal, irreversible injury**.



Designates a **potentially harmful situation**. If this potentially harmful situation is not avoided, **the product or something in its vicinity may be damaged**.

2.4.1 Symbols used



Warning symbol, suspended load

Fig. 1: Warning symbol, suspended load



Warning symbol, explosive atmosphere

Fig. 2: Warning symbol, explosive atmosphere



Warning symbol, hazardous substances

Fig. 3: Warning symbol, hazardous substances



Warning symbol, hot surface

Fig. 4: Warning symbol, hot surface



Warning symbol, hand injuries

Fig. 5: Warning symbol, hand injuries



Mandatory symbol, wear foot protection

Fig. 6: Mandatory symbol, wear foot protection



Mandatory symbol, wear ear protection

Fig. 7: Mandatory symbol, wear ear protection

General safety information

Special dangers

2.4.2 User information



Information that refers to technical and commercial requirements. Non-adherence can lead to faults and production down-time.

2.5 Special dangers



Fig. 8: Warning symbol, explosive atmosphere



DANGER!

Insufficient functioning of the product due to improper assembly, maintenance or inspection. Danger to life due to spreading substances which are explosive and/or hazardous to health!



Fig. 9: Warning symbol, hazardous substances



CAUTION!

Preparation for assembly, functionality test, inspections and/or maintenance

- A **decontamination declaration** must be completed prior to inspection and/or maintenance work and must confirm that the product has been cleaned and no longer contains any residual substances that are harmful to health.
- If the product comes into contact with substances that are harmful to health, these substances must be entered in the decontamination declaration.
- The decontamination declaration may only be filled out and signed by the operator's authorised specialists.
- The decontamination declaration must be sent to RICO before the start of maintenance and/or inspection work (if activities are performed by RICO).
- Before carrying out any work on the product, it must be ensured that the **gas generator is securely** locked in position.
- Before carrying out any work on the product, it must be ensured that the product has cooled down.



Fig. 10: Warning symbol, hand injuries



DANGER!

Please do **not** reach into the explosion protection slide valve if it is not in a secured state. Reaching into it could result in serious hand injuries. For this reason, please put the slide valve in the "secured" position before you perform work on the explosion protection slide valve.



Fig. 11: Warning symbol, hot surface

2.6 Combination with other products



*The slide valve may only be combined with other products if the following points are considered and complied with. **If this is not the case, the function of the slide valve cannot be ensured.***

- *This applies to the combination with the following RICO products:*
 - *Explosion protection slide valve **RSV***
 - *Explosion protection valve **VENTEX ESI-P***
- *All gas generators which are connected in parallel or in series, or which can be triggered by the same controller, **must have the same ignition current.***

If this is the case, we request that you contact us at info@rico.ch so that we can advise you in this respect.

3 Product description of RSV-D

The slide valve is used to isolate a pipe section in the event of an explosion.



According to Machinery Directive 2006/42/EC, the slide valve is an **incomplete machine**.

3.1 Functional principle

During normal operation, the medium flows through a pipeline and through the slide valve when the slide valve is in the “open” position.

One or more sensors are located on the pipeline or the equipment to be protected, in the direction of the explosion upstream of the slide valve. These detect an explosion should one occur. The sensors are connected to a controller, which evaluates the data from the sensors. The slide valve is also connected to the controller. These components are not part of the slide valve, and instead belong to the complete protection system. These components will therefore not be discussed in further detail here.

If the controller reports an explosion to the slide valve, one or more gas generators located in the slide valve will be ignited depending on the nominal width. The ignition of the gas generators generates a pressure inside the slide valve, which immediately puts the slide blade into a rapid movement. As a result, the slide valve or the passage of the pipe is closed and the explosion is prevented from spreading.

3.2 Pressure shock-resistant design



NOTICE!

The slide valve has a **pressure shock-resistant design**. This means that the slide valve always has to be inspected after an explosion and any damaged parts or the entire slide valve must be replaced. If there is no inspection by a trained service technician or RICO Sicherheitstechnik AG, there is a risk that the slide valve will no longer perform its function.

3.3 ATEX zones



Fig. 12: Ex mark

- Test number DN50–DN150: **FSA 17 ATEX 1669 X**
- Test number DN200–DN300: **FSA 17 ATEX 1671 X**
- Test number DN400: **FSA 17 ATEX 1673 X**
- Test number DN500: **FSA 18 ATEX 1692 X**
- Equipment group: II
- Equipment category: 1D
- Protection system: D
- Zone inside: 20, 21, 22
- Zone outside: Depending on the add-on parts, e.g. switches

The relevant marking is specified by FSA GmbH, Dynamostr. 7-11, 68165 Mannheim, Germany.

3.4 Explosion pressure and process temperature

- Explosion pressure: See installation guideline MT0009DE / MT0009GB
- Maximum process temperature: See installation guideline MT0009DE / MT0009GB
- RSV closing times: See closing times overview MD0019DE / MD0019GB

3.5 Media



NOTICE!

The slide valve may only be operated using the media described in the **installation guideline MT0009DE** for German or **MT0009GB** for English. On no account is the slide valve to be used using fluids. If you do not have the applicable installation guideline anymore, please contact us at info@rico.ch.

3.6 Technical data

3.6.1 Technical data sheet & installation guideline

The scope of delivery of every slide valve includes an appropriate **technical data sheet**, which contains supplementary technical data.

See **installation guideline MT0009DE** for German, or **MT0009GB** for English. If these are not available, please contact us at info@rico.ch.

Product description of RSV-D

Technical data > Switches

3.6.2 Assembly diagram & parts list

The scope of supply for the slide valve includes an assembly drawing and a parts list showing or describing the technical structure of the slide valve.

3.6.3 Name plate

A name plate is affixed to every slide valve. This contains the following information:

- Manufacturer
- Classification
- Fabrication number
- Fabrication year
- Part number
- Max. operating temperature
- Temperature-dependent pressure load
- Permissible ambient temperatures
- ATEX zone inside / ATEX zone outside

Additionally, the fabrication number is marked on the housing of the slide valve.

3.6.4 Gas generator



DANGER!

Pay attention to the regulations when working with the gas generator.

- **EC safety data sheet**
TRWMS 30377371/ERD 182266
- **VDA recommendation**
11-007 safety data sheet

3.6.5 Switches

See separate description from the switch manufacturer.

4 Product description of RSV-G

The slide valve is used to isolate a pipe section in the event of an explosion.



According to Machinery Directive 2006/42/EC, the slide valve is an **incomplete machine**.

4.1 Functional principle

During normal operation, the medium flows through a pipeline and through the slide valve when the slide valve is in the “open” position.

One or more sensors are located on the pipeline or the equipment to be protected, in the direction of the explosion upstream of the slide valve. These detect an explosion should one occur. The sensors are connected to a controller, which evaluates the data from the sensors. The slide valve is also connected to the controller. These components are not part of the slide valve, and instead belong to the complete protection system. These components will therefore not be discussed in further detail here.

If the controller reports an explosion to the slide valve, one or more gas generators located in the slide valve will be ignited depending on the nominal width. The ignition of the gas generators generates a pressure inside the slide valve, which immediately puts the slide blade into a rapid movement. As a result, the slide valve or the passage of the pipe is closed and the explosion is prevented from spreading.

4.2 Pressure shock-resistant design



NOTICE!

The slide valve has a **pressure shock-resistant design**. This means that the slide valve always has to be inspected after an explosion and any damaged parts or the entire slide valve must be replaced. If there is no inspection by a trained service technician or RICO Sicherheitstechnik AG, there is a risk that the slide valve will no longer perform its function.

Product description of RSV-G

Technical data > Technical data sheet & installation guideline

4.3 ATEX zones



Fig. 13: Ex mark

- Test number DN50–DN150: **FSA 17 ATEX 1670 X**
- Test number DN200–DN300: **FSA 17 ATEX 1672 X**
- Test number DN400: **FSA 17 ATEX 1674 X**
- Equipment group: II
- Equipment category: 1GD
- Protection system: D
- Zone inside: 0, 1, 2, 20, 21, 22
- Zone outside: Depending on the add-on parts, e.g. switches

The relevant marking is specified by FSA GmbH, Dynamostr. 7-11, 68165 Mannheim, Germany.

4.4 Explosion pressure and process temperature

- Explosion pressure: See installation guideline MT0009DE / MT0009GB
- Maximum process temperature: See installation guideline MT0009DE / MT0009GB
- Inliner: See installation guideline MD0026DE / MD0026GB
- RSV closing times: See closing times overview MD0019DE / MD0019GB

4.5 Media



NOTICE!

The slide valve may only be operated using the media described in the **installation guideline MT0009DE** for German or **MT0009GB** for English. On no account is the slide valve to be used using fluids. If you do not have the applicable installation guideline anymore, please contact us at info@rico.ch.

4.6 Technical data

4.6.1 Technical data sheet & installation guideline

The scope of delivery of every slide valve includes an appropriate **technical data sheet**, which contains supplementary technical data.

See **installation guideline MT0009DE** for German, or **MT0009GB** for English. If these are not available, please contact us at info@rico.ch.

4.6.2 Assembly diagram & parts list

The scope of supply for the slide valve includes an assembly drawing and a parts list showing or describing the technical structure of the slide valve.

4.6.3 Name plate

A name plate is affixed to every slide valve. This contains the following information:

- Manufacturer
- Classification
- Fabrication number
- Fabrication year
- Part number
- Max. operating temperature
- Temperature-dependent pressure load
- Permissible ambient temperatures
- ATEX zone inside / ATEX zone outside

Additionally, the fabrication number is marked on the housing of the slide valve.

4.6.4 Gas generator



DANGER!

Pay attention to the regulations when working with the gas generator.

- **EC safety data sheet**
TRWMS 30377371/ERD 182266
- **VDA recommendation**
11-007 safety data sheet

4.6.5 Switches

See separate description from the switch manufacturer.

5 Product description of RSV-P

The slide valve is used to isolate a pipe section in the event of an explosion.



According to Machinery Directive 2006/42/EC, the slide valve is an **incomplete machine**.

5.1 Functional principle

During normal operation, the medium flows through a pipeline and through the slide valve when the slide valve is in the “open” position.

One or more sensors are located on the pipeline or the equipment to be protected, in the direction of the explosion upstream of the slide valve. These detect an explosion should one occur. The sensors are connected to a controller, which evaluates the data from the sensors. The slide valve is also connected to the controller. These components are not part of the slide valve, and instead belong to the complete protection system. These components will therefore not be discussed in further detail here.

If the controller reports an explosion to the slide valve, one or more gas generators located in the slide valve will be ignited depending on the nominal width. The ignition of the gas generators generates a pressure inside the slide valve, which immediately puts the slide blade into a rapid movement. As a result, the slide valve or the passage of the pipe is closed and the explosion is prevented from spreading.

5.2 Pressure shock-resistant design



NOTICE!

The slide valve has a **pressure shock-resistant design**. This means that the slide valve always has to be inspected after an explosion and any damaged parts or the entire slide valve must be replaced. If there is no inspection by a trained service technician or RICO Sicherheitstechnik AG, there is a risk that the slide valve will no longer perform its function.

5.3 ATEX zones



Fig. 14: Ex mark

- Test number DN50–DN150: **FSA 17 ATEX 1670 X**
- Test number DN200–DN300: **FSA 17 ATEX 1672 X**
- Test number DN400: **FSA 17 ATEX 1674 X**
- Equipment group: II
- Equipment category: 1GD
- Protection system: D
- Zone inside: 0, 1, 2, 20, 21, 22
- Zone outside: Depending on the add-on parts, e.g. switches

The relevant marking is specified by FSA GmbH, Dynamostr. 7-11, 68165 Mannheim, Germany.

5.4 Explosion pressure and process temperature

- Explosion pressure: See installation guideline MT0009DE / MT0009GB
- Maximum process temperature: See installation guideline MT0009DE / MT0009GB
- Inliner: See installation guideline MD0026DE / MD0026GB
- RSV closing times: See closing times overview MD0019DE / MD0019GB

5.5 Media



NOTICE!

The slide valve may only be operated using the media described in the **installation guideline MT0009DE** for German or **MT0009GB** for English. On no account is the slide valve to be used using fluids. If you do not have the applicable installation guideline anymore, please contact us at info@rico.ch.

5.6 Technical data

5.6.1 Technical data sheet & installation guideline

The scope of delivery of every slide valve includes an appropriate **technical data sheet**, which contains supplementary technical data.

See **installation guideline MT0009DE** for German, or **MT0009GB** for English. If these are not available, please contact us at info@rico.ch.

Product description of RSV-P

Technical data > Switches

5.6.2 Assembly diagram & parts list

The scope of supply for the slide valve includes an assembly drawing and a parts list showing or describing the technical structure of the slide valve.

5.6.3 Name plate

A name plate is affixed to every slide valve. This contains the following information:

- Manufacturer
- Classification
- Fabrication number
- Fabrication year
- Part number
- Max. operating temperature
- Temperature-dependent pressure load
- Permissible ambient temperatures
- ATEX zone inside / ATEX zone outside

Additionally, the fabrication number is marked on the housing of the slide valve.

5.6.4 Gas generator



DANGER!

Pay attention to the regulations when working with the gas generator.

- **EC safety data sheet**
TRWMS 30377371/ERD 182266
- **VDA recommendation**
11-007 safety data sheet

5.6.5 Switches

See separate description from the switch manufacturer.

6 Assembly of RSV-D/RSV-G and RSV-P

6.1 Assembly advice



NOTICE!

To prevent stresses on the slide blade during the closing process, the slide valve must be secured to the fastening threads, which are provided on the housing. The fastening must be able to independently bear double the weight of the slide valve.

The pipelines must be aligned in a straight line and have no offset.

During assembly, ensure good access and easy disassembly possibilities for inspections. A pipe section measuring 1 m long should also be installed on at least one side of the slide valve. To simplify maintenance, these pipe sections can be dismantled if needed. If this is not possible, a service hatch should be positioned upstream of the slide valve on the pipe.



NOTICE!

The slide valve must not be insulated or heated as this could cause an increase of temperature in the gas generator. The maximum limit for the gas generator is 60 °C. The service life of the gas generator is reduced significantly by higher temperatures due to the accelerated decomposition of the propellant. ↪ *Chapter 3.6.4 'Gas generator' on page 18*

6.2 Direction of explosion



The slide valve has a dual action, i.e. it can isolate explosions from both sides if the sensors are designed accordingly. There is therefore no need to pay attention to the direction of explosion.

Assembly of RSV-D/RSV-G and RSV-P

Tightening torques

6.3 Installation position



The slide valve is designed so that it can be installed in any position. The closing times or installation distances specified by RICO Sicherheitstechnik AG have been tested in the worst-case scenario.

6.4 Tightening torques



NOTICE!

Use a torque wrench for assembly and pay attention to the permitted tightening torques of the screw connections.

Tab. 1: Torque of RSV-D/RSV-G and RSV-P

Screw	Torque [Nm]
M6	5 Nm
M12	40 Nm
M16	96 Nm
M20	190 Nm
G1/4"	32 Nm

Aids required

- Loctite 577
- Loctite 290
- Klüber Wolfracoat C or similar
- Leaking spray

Tool required

- Face spanner (included in the delivery)
- Pliers
- Commercially available tool

6.5 Electrical connections



Fig. 15: Earthing

Earth and **wire** the junction box **according to the electric circuit diagram**, which is included in the scope of delivery.



Then tighten the cable glands to produce a tight termination. Make sure that the cover of the connecting socket sits correctly.

6.6 Compressed air



*For pneumatic actuation, only use compressed air that is **dry and free from water and oil** as per DIN/ISO 8573-1 Class 1.*

6.7 Welding work



NOTICE!

When welding the pipe, the plug-in connector must be removed to prevent ignition of the gas generators.

Set the slide valve to the “secured” position if it is not already in this position.

Unplug the ignition cable.

Remove the plug-in connector for the gas generator by loosening the safeguard and pulling out the plug-in connector.



IMPORTANT

The pipe must be earthed.

7 Commissioning RSV-D

7.1 Commissioning

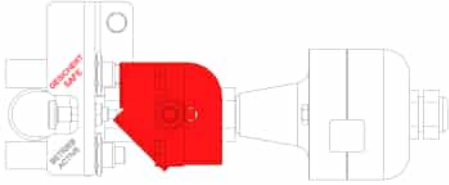

Fig. 16: Gas generator holder in "secured" position

1. ➤ Set the slide valve to the "secured" position if it is not already in this position.
 - Remove the cover of the cladding of the gas generator holder and put it aside with the screws.
 - Tighten the locking bolt, hold it firmly and turn the ball valve simultaneously so that the cam switch sends a signal for the "secured" position via the switch.

⇒ The explosion protection slide valve is now secured and work can be carried out on it.



All explosion protection slide valves are delivered in the "secured" position for safety reasons.

2. ➤ Exchange the locking screws for the plug nipple included in the delivery:
 - Remove both locking screws.
 - Screw the locking screws at the place provided for them (on the switch for the "secured" position).
3. ➤ Wire the slide valve via the junction box to the controller according to the electric diagram included in the delivery.
4. ➤ Remove the electric bridge according to the electric diagram.
5. ➤ Perform the functionality test according to the "Functionality test" guide.
6. ➤ The slide valve is now ready for use.

7.2 Functionality test

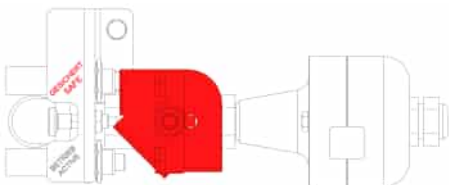

Fig. 17: Gas generator holder in "secured" position

1. ➤ Set the slide valve to the "secured" position if it is not already in this position.
 - Remove the cover of the cladding of the gas generator holder and put it aside with the screws.
 - Tighten the locking bolt, hold it firmly and turn the ball valve simultaneously so that the cam switch sends a signal for the "secured" position via the switch.
If not, check the switches, cables and connections for damage and replace them if need be.

⇒ The explosion protection slide valve is now secured and work can be carried out on it.
2. ➤ Remove the guard plate at the side, which protects the switches from damage, by loosening the two hexagon screws. Put the screws and guard plate aside.

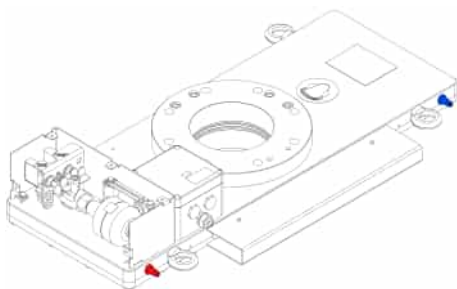

Fig. 18: RSV with plug nipple for OPEN (blue) and CLOSED (red)

3. Pneumatically actuate the slide valve.

The following statements describe the pneumatic actuation of a slide valve in its basic design:

- Connect a self-locking coupling to the plug nipple where "ZU/CLOSE" is engraved on the housing. Use a pressure controller here, if available.
- Check whether the slide blade can be moved with 6 bar or if it can be moved to the closed position. If the slide valve cannot be closed with 6 bar, it must be inspected.
- In the closed position, check whether your controller is receiving a signal.

If not, check the switches, cables and connections for damage and replace them if need be.

- Now connect a self-locking coupling to the plug nipple where "AUF/OPEN" is engraved on the housing. Please refer to the information section below for details of the dwell time in the end positions. Then open the slide valve again.
 - In the open position, check whether your controller is receiving a signal.
- If not, check the switches, cables and connections for damage and replace them if need be.



Activation pressure

The pneumatic pressure for activating the slide valve must be **6 bar**. The pneumatic closing or opening time must be ≤ 6 s and should be measured using the controller.



Dwell time in position "AUF/OPEN" / "ZU/CLOSE"

In the open and close position, please observe a dwell time of at least **1 minute**.

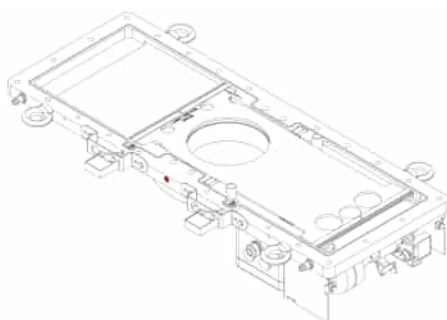

Fig. 19: Non-return valve

4. Checking the non-return valve for a water leak

After pneumatic activation, check if water is leaking at the non-return valve.

If so, the slide valve and compressed air supply must be checked immediately.

Commissioning RSV-D

Functionality test

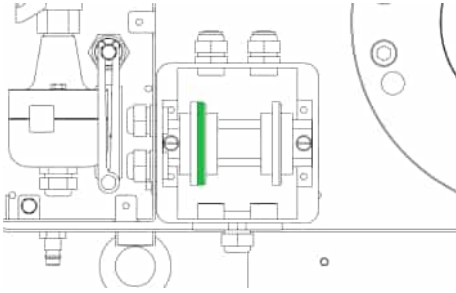

Fig. 20: PE terminal

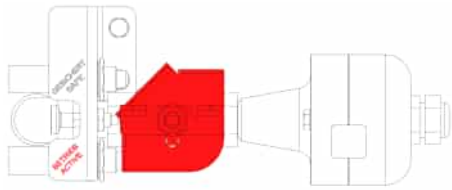

Fig. 21: "Active" position of gas generator holder

5. ▶ Checking the earthing
Check if the slide blade is earthed by measuring the resistance from the earthing terminal in the junction box to the slide blade ($\leq 1 \text{ ohm}$).
6. ▶ Check the prescribed screw tightening torques ↪ *Chapter 6.4 'Tightening torques' on page 26*
7. ▶ Bring the slide valve or ball valve to the "active" position and check if the switch is receiving a signal for the "active" position.
If not, check the switches, cables and connections for damage and replace them if need be.
8. ▶ Upon completion of the functionality test, the plug nipples need to be removed again and the pneumatic holes need to be sealed by means of locking screws.
9. ▶ Assemble all the covers removed earlier using the screws provided for this purpose.
⇒ **If the functionality test is passed successfully, the slide valve can be put into operation.**



Sensors

The use of sensors in an outdoor explosion zone is only permitted during intrinsically safe operation.



RSV-D set gas-tight test

Blind flanges must also be installed to perform the gas-tight test of the housing in RSV-D. These are not included in the scope of delivery.

8 Maintenance of RSV-D

8.1 Maintenance



The maintenance intervals are dependent on the operating conditions of the slide valve.

*We recommend that you do not actuate the slide valve pneumatically outside the maintenance intervals, in order to prevent the ingress of dust inside the slide valve. However, please ensure that the slide valve **is pneumatically actuated at least once a year.***



WARNING!

Maintenance and inspections in Ex zones

Maintenance and inspections must not be carried out in Ex zones. If this is not possible, appropriate safety measures must be taken and suitable tools must be used.

Maintenance intervals to be observed

Interval	Maintenance work
a) 3 to 5 days after commissioning	Functionality test
b) 3 months	Functionality test, visual and wear monitoring
c) Annually or depending on process	Functionality test, visual and wear monitoring
c) Every 8 years	The gas generator must be replaced no later than after 8 years (see chapter "Gas generator").
d) Every 5 years	All seals must be replaced no later than after 5 years.



Replacing the slide blade

After 10 activations by gas generators, the entire slide blade and the spring-loaded ball bearing must be replaced.



Activation in secured position

In the event of possible activation in the "secured" position, the entire gas generator holder unit must be replaced.

8.1.1 Test process after an explosion/fire

After an explosion or fire, the device must be inspected in accordance with the MB0008 instruction manual and the following points must be checked:

Check of the housing

- Check for deformation of the housing on the outside (across the entire length of the housing)
 - Evenness ≤ 0.5 mm (DN50–DN150)
 - Evenness ≤ 0.8 mm (DN200–DN300)
 - Evenness ≤ 1.0 mm (DN400–DN500)

Check of the flange

- Check for deformation of the flange
 - The axial true running of the flange, from the bearing face to the sealing face, must be ≤ 0.05 mm.

The following parts must be replaced

- – Entire slide blade
- Screw connections
- All seals
- Springs
- Ball bearings
- Non-return valves

Measuring equipment required

- – Measuring table
- Dial gauge, 0.01 mm

Tools required

- – Feeler gauge from 0.1 mm to 1.0 mm
- Hand pump with pressure gauge
- Set of open-ended wrenches from 10 mm to 27 mm
- Set of Allen keys from 4 mm to 17 mm

8.2 Recurring maintenance

8.2.1 Functionality test

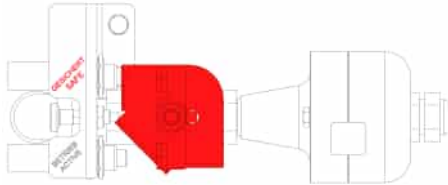

Fig. 22: Gas generator holder in "secured" position

- 1.** ➤ Set the slide valve to the "secured" position if it is not already in this position.
 - Remove the cover of the cladding of the gas generator holder and put it aside with the screws.
 - Tighten the locking bolt, hold it firmly and turn the ball valve simultaneously so that the cam switch sends a signal for the "secured" position via the switch.
If not, check the switches, cables and connections for damage and replace them if need be.

⇒ The explosion protection slide valve is now secured and work can be carried out on it.
- 2.** ➤ Remove the guard plate at the side, which protects the switches from damage, by loosening the two hexagon screws. Put the screws and guard plate aside.

Maintenance of RSV-D

Recurring maintenance > Functionality test

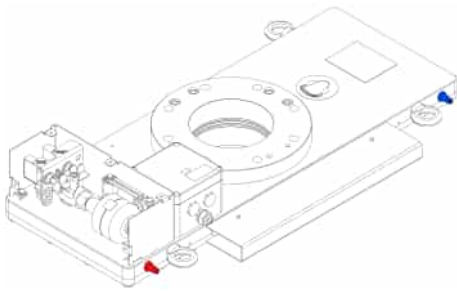

Fig. 23: RSV with plug nipple for OPEN (blue) and CLOSED (red)

3. Pneumatically actuate the slide valve.

The following statements describe the pneumatic actuation of a slide valve in its basic design:

- Connect a self-locking coupling to the plug nipple where "ZU/CLOSE" is engraved on the housing. Use a pressure controller here, if available.
- Check whether the slide blade can be moved with 6 bar or if it can be moved to the closed position. If the slide valve cannot be closed with 6 bar, it must be inspected.
- In the closed position, check whether your controller is receiving a signal.

If not, check the switches, cables and connections for damage and replace them if need be.

- Now connect a self-locking coupling to the plug nipple where "AUF/OPEN" is engraved on the housing. Please refer to the information section below for details of the dwell time in the end positions. Then open the slide valve again.
- In the open position, check whether your controller is receiving a signal.

If not, check the switches, cables and connections for damage and replace them if need be.



Activation pressure

*The pneumatic pressure for activating the slide valve must be **6 bar**. The pneumatic closing or opening time must be ≤ 6 s and should be measured using the controller.*



Dwell time in position "AUF/OPEN" / "ZU/CLOSE"

*In the open and close position, please observe a dwell time of at least **1 minute**.*

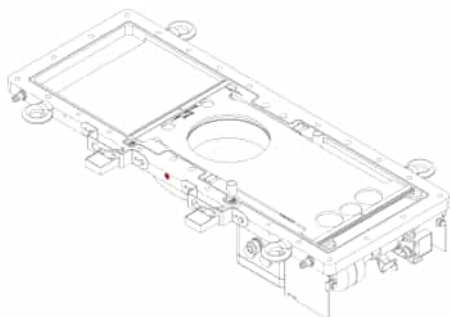

Fig. 24: Non-return valve

4. Checking the non-return valve for a water leak

After pneumatic activation, check if water is leaking at the non-return valve.

If so, the slide valve and compressed air supply must be checked immediately.

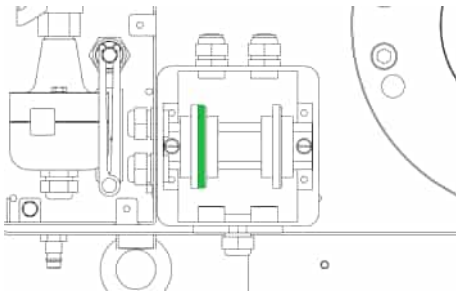

Fig. 25: PE terminal

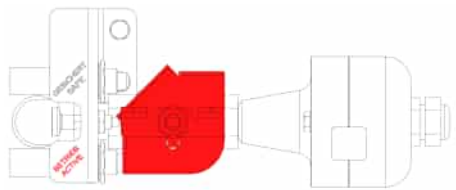

Fig. 26: "Active" position of gas generator holder

5. ➤ Checking the earthing
Check if the slide blade is earthed by measuring the resistance from the earthing terminal in the junction box to the slide blade ($\leq 1 \text{ ohm}$).
6. ➤ Check the prescribed screw tightening torques ↪ *Chapter 6.4 'Tightening torques' on page 26*
7. ➤ Bring the slide valve or ball valve to the "active" position and check if the switch is receiving a signal for the "active" position.
If not, check the switches, cables and connections for damage and replace them if need be.
8. ➤ Upon completion of the functionality test, the plug nipples need to be removed again and the pneumatic holes need to be sealed by means of locking screws.
9. ➤ Assemble all the covers removed earlier using the screws provided for this purpose.
⇒ **If the functionality test is passed successfully, the slide valve can be put into operation.**



Sensors

The use of sensors in an outdoor explosion zone is only permitted during intrinsically safe operation.



RSV-D set gas-tight test

Blind flanges must also be installed to perform the gas-tight test of the housing in RSV-D. These are not included in the scope of delivery.

8.2.2 Visual check and wear monitoring

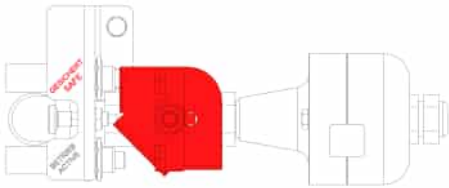

Fig. 27: Gas generator holder in "secured" position

1. ➤ Set the slide valve to the "secured" position if it is not already in this position.

- Remove the cover of the cladding of the gas generator holder and put it aside with the screws.
- Tighten the locking bolt, hold it firmly and turn the ball valve simultaneously so that the cam switch sends a signal for the "secured" position via the switch.
If not, check the switches, cables and connections for damage and replace them if need be.

⇒ The explosion protection slide valve is now secured and work can be carried out on it.

2. ➤ Check the housing, passage and junction box for corrosion and mechanical damage.

3. ➤ Check for impurities and deposits

Check whether deposits are present in the area of the lead-through or flanges.

If there are, clean the passage with a cloth moistened with soapy water and then dry it.

4. ➤ Checking the gap dimensions

Check the gap between the slide blade and the active seals.

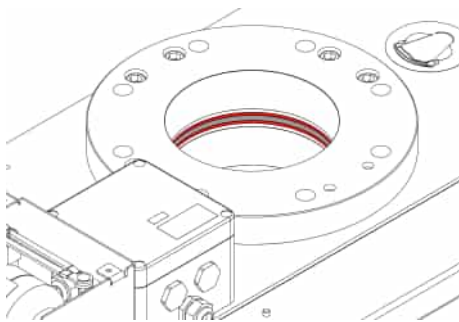

Fig. 28: RSV-D slide blade (grey) and active seal (red)



Gap dimensions

The following gap dimensions are permissible:

- Good: $< 0.05 \text{ mm}$
- Bad: $\geq 0.05 \text{ mm}$

If the maximum permissible gap dimensions are exceeded, the active seals must be replaced and the flanges must be adjusted. ↪ *Chapter 9.3 'Replace the active seals' on page 43*

5. ➤ Flange seal check

Check the flange seals for visible damage.

If they are damaged, they must be replaced.

9 Inspection of RSV-D



NOTICE!

Explosive event

The slide valve must be **inspected after every explosion**, when it shows **signs of wear** or **after 5 years**.

Otherwise the function of the slide valve is not ensured.



WARNING!

Maintenance and inspections in Ex zones

Maintenance and inspections must not be carried out in Ex zones. If this is not possible, appropriate safety measures must be taken and suitable tools must be used.

9.1 Gas generator replacement

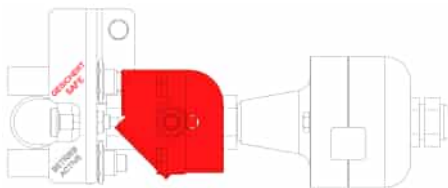

Fig. 29: Gas generator holder in "secured" position

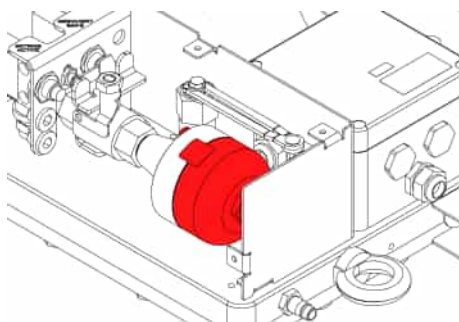

Fig. 30: Cap for gas generator holder

1. ➔ Set the slide valve to the "secured" position if it is not already in this position.
 - Remove the cover of the cladding of the gas generator holder and put it aside with the screws.
 - Tighten the locking bolt, hold it firmly and turn the ball valve simultaneously so that the cam switch sends a signal for the "secured" position via the switch.
2. ➔ Remove the hologram sticker between the cap and gas generator holder.
3. ➔ Remove the hexagon screws holding the cap in place. Remove the cap.

Inspection of RSV-D

Gas generator replacement

4. ▶ Unplug the ignition cable

Remove the plug-in connector for the gas generator by loosening the fuse and pulling out the plug-in connector.

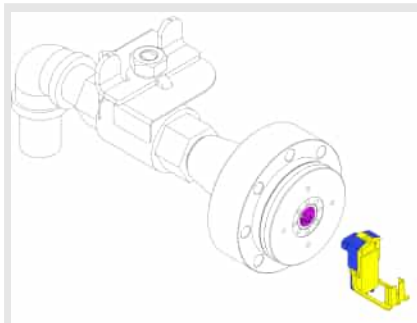

Plug for RSV DN50–DN150 unplugged

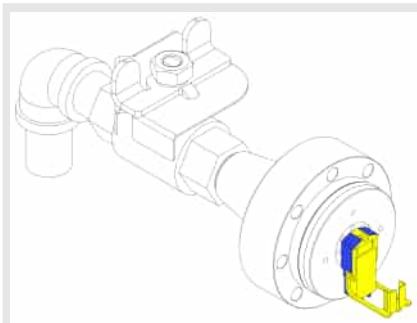

Plug for RSV DN50–DN150 **single**-plugged

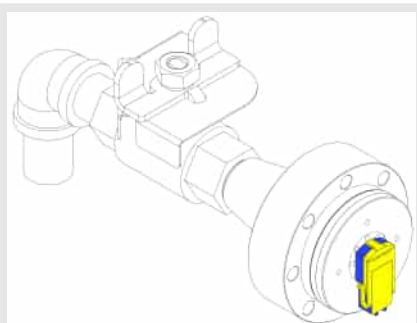

Plug for RSV DN50–DN150 **double**-plugged

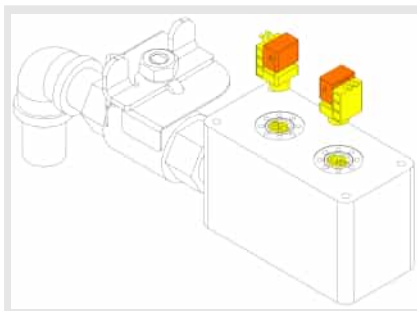

Plug for RSV DN200–DN400 unplugged

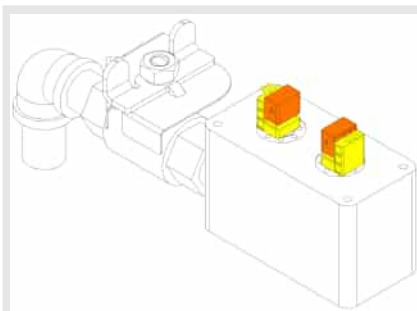

Plug for RSV DN200–DN400 **single**-plugged

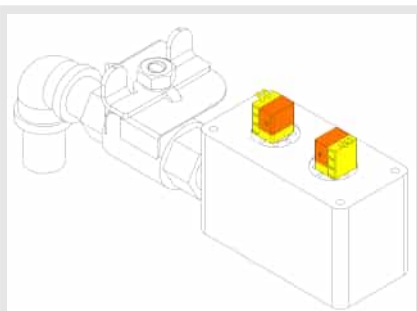

Plug for RSV DN200–DN400 **double**-plugged

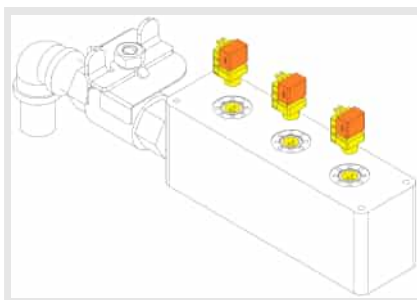

Plug for RSV DN500 unplugged

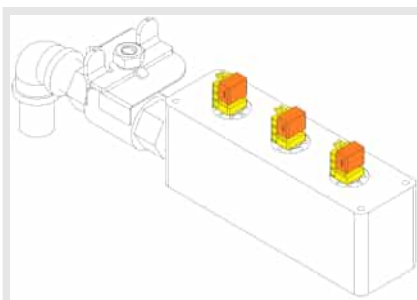

Plug for RSV DN500 **single**-plugged

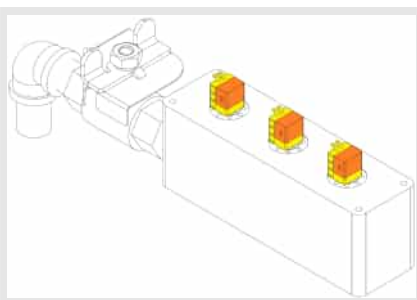

Plug for RSV DN500 **double**-plugged

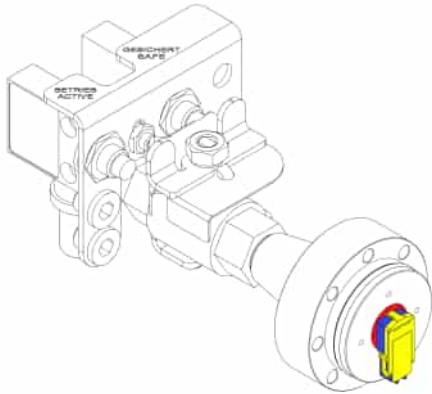

Fig. 31: Spark plug (yellow, blue) and locking screw (red)

5. ➤ Remove the gas generator
 - Take the face spanner included in the delivery out of its holder.
 - Loosen the locking screw from the gas generator holder and remove it.
 - Remove the activated gas generator with pliers and dispose of it. ↪ *Chapter 16 'Disposing of RSV-D / RSV-G and RSV-P' on page 111*
6. ➤ Remove gas generator residue
 - Move the ball valve into the "active" position.
 - Apply 6 bar compressed air to the slide valve in this position via the pneumatic connection "ZU/CLOSE" for 15 seconds.
 - ⇒ Any gas generator residue must now be blown out from the gas generator holder and housing.
7. ➤ Before continuing with the work, move the ball valve or slide valve back into the "secured" position.

Inspection of RSV-D

Gas generator replacement

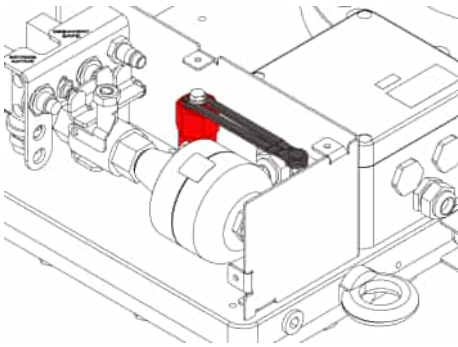

Fig. 32: Spare gas generator holder (red) and face pin wrench

8. Insert the gas generator

- Remove the new gas generator(s) (depending on their nominal width) from the spare gas generator holder by unscrewing it/them.
- Remove the new gas generators, buffers and hologram stickers.
- Apply a little high-temperature grease (e.g. Klüber Wolf-racoat C) to the gas generator.
Insert the new gas generator(s) (depending on their nominal width) and re-tighten with the locking screw.
- Plug the ignition cable(s) back in so that it locks in place twice.
- **Place the cap of the generator on it and fix it again with its hexagon screws.**
- Stick one of the new hologram labels on the cap and gas generator holder.
- Screw back the empty spare gas generator holder and face spanner into the positions provided for this.



Gas generator charge 0.8 g
DN50–DN150 **Article no.**
010138

Gas generator charge 1.3 g
DN200–DN500 **Article no.**
126323



Reactivation kit

Order new gas generators, buffers and hologram stickers immediately. For this, use the MF0006DE form, which can be downloaded at www.service.rico.ch or <http://www.rico.ch/de/download>.

Ensure that the new gas generators and buffers reach the spare gas generator holders provided for this right away and are thus always available.



CAUTION!

Do not move the ball valve or slide valve into the “active” position yet.

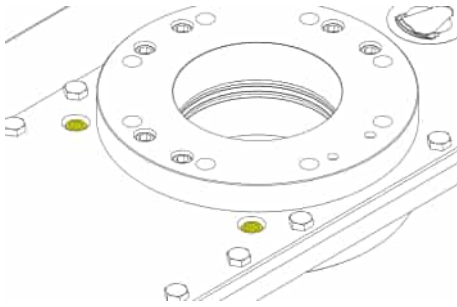

Fig. 33: Buffer without locking keys

9. Replace the buffers

- Remove the locking screw on the upper housing and put it aside.
- Move the slide valve or slide blade to the “open” position according to the functional test. ↪ *Chapter 8.2.1 ‘Functionality test’ on page 33*
If this is not successful, extend the buffers using a large screwdriver, so that the slide valve can be actuated or opened pneumatically.
- Remove the destroyed buffers using pliers and/or a screwdriver.
- Insert the new buffers included in the delivery.
- Re-tighten the locking screws firmly.

10. Change hologram stickers on the housing

- Remove the lateral guard plate.
- Remove the existing hologram sticker and replace it with the new one so that it has the same number as the sticker on the gas generator holder.
- Fit the lateral guard plate back.

11. Move the slide valve into the “active” position

Move the slide valve or ball valve back into the “active” position.

12. Fit the cover of the gas generator holder.

⇒ **The slide valve is ready for operation again.**

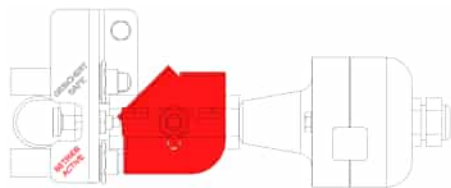

Fig. 34: “Active” position of gas generator holder

9.2 Replacing the gas generator holder

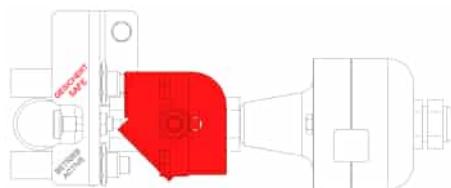

Fig. 35: Gas generator holder in “secured” position

1. Set the slide valve to the “secured” position if it is not already in this position.

- Remove the cover of the cladding of the gas generator holder and put it aside with the screws.
- Tighten the locking bolt, hold it firmly and turn the ball valve simultaneously so that the cam switch sends a signal for the “secured” position via the switch.

2. Remove the hologram sticker between the cap and gas generator holder.

3. Remove the hexagon screws holding the cap in place. Remove the cap.

4. Unplug the ignition cable

Remove the plug-in connector for the gas generator by loosening the safeguard and pulling out the plug-in connector.

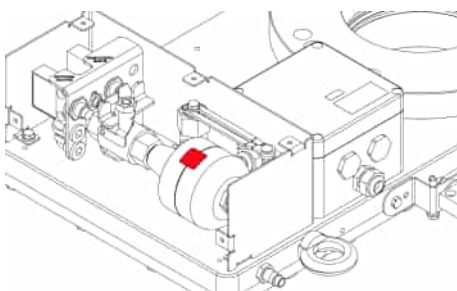

Fig. 36: Hologram stickers

Inspection of RSV-D

Replacing the gas generator holder

5. ▶ Remove the gas generator

- Take the face spanner included in the delivery out of its holder.
- Loosen the locking screw from the gas generator holder and remove it.
- Remove the activated gas generator with pliers and dispose of it. ⚠ 'Ignited gas generators' on page 111

6. ▶ Remove the junction box

- Open the junction box by loosening the four screws.
- Remove the junction box by loosening the four cylinder head screws inside the junction box.



There is no need to interfere with the cables.

- Remove the entire cladding of the gas generator holder.
- Remove the spare gas generator holder.
- Remove the holder of both switches for the position "active" and "secured", and the earthing cable.

⇒ The gas generator holder is now free.

7. ▶ Remove the gas generator holder

- Heat the fitting with a hot air dryer so that it can be "unlocked" and loosened.
- Turn the gas generator holder including the threaded fitting until it can be removed, and dispose of the gas generator holder.

8. ▶ Via the pneumatic connection "ZU/CLOSE", apply 6 bar compressed air to the slide valve for 15 seconds in this position. This will blow out any residue from the gas generator.

9. ▶ Coat the thread fitting with Loctite 577 thread sealant.

10. ▶ Now, screw on the new gas generator holder so that the axis of the ball valve is parallel to the housing.

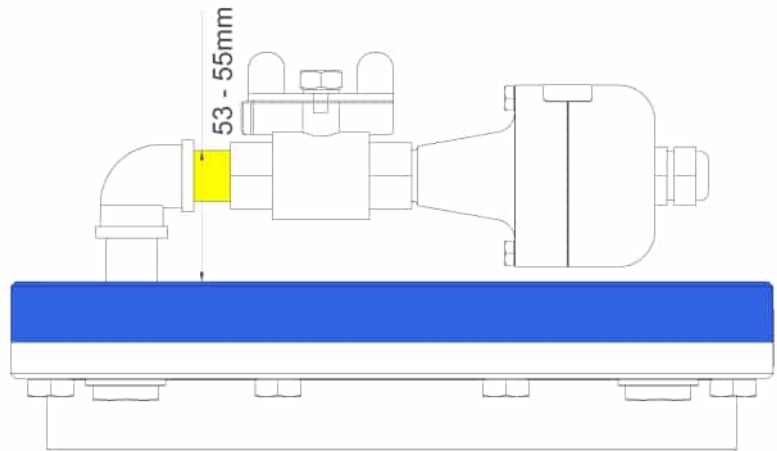

Fig. 37: Installation height, RSV gas generator holder

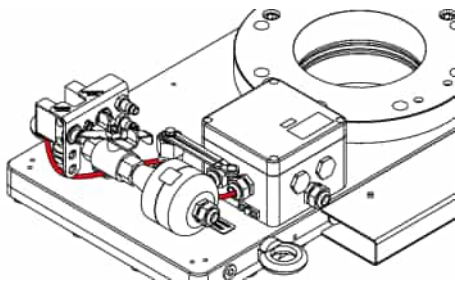

Fig. 38: Route of switch cable

11. ➤ Install the universal holder, cladding, junction box and spare gas generator holder.

Install the switch holder with the earthing. Ensure that the cable between the junction box and switch holder goes under the gas generator holder and switch holder.

12. ➤ Now, move the ball valve or **slide valve back into the "secured" position.**
13. ➤ Assemble or fix the cladding of the gas generator holder again.
14. ➤ Fit and connect the junction box back correctly.
15. ➤ Continue according to [Chapter 9.1 'Gas generator replacement'](#) on page 37, point 8 "Inserting the gas generator".

9.3 Replace the active seals

1. ➤ Set the slide valve to the "secured" position if it is not already in this position.
 - Remove the cover of the cladding of the gas generator holder and put it aside with the screws.
 - Tighten the locking bolt, hold it firmly and turn the ball valve simultaneously so that the cam switch sends a signal for the "secured" position via the switch.

Inspection of RSV-D

Replacing the seals on the housing and gas generator holder

2. ▶ Remove the flange connection

First remove a flange, change the seals and repeat the next steps for the other side.

- Loosen and remove all screws on the respective flange.
- On the other side, loosen and remove only those screws that have through-holes.



If there were shim rings on the side on which you just removed the flange, re-insert them in the same position when assembling the flange.

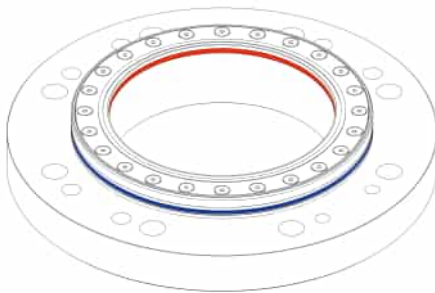

Fig. 39: RSV-D flange seal inner (red) and outer (blue)

3. ▶ On the exposed flange, remove the disc-shaped active seal and both inner and outer flange seals.

4. ▶ Clean the flange using a cloth moistened with soapy water.

5. ▶ Fit the new seals in reverse order. Secure the locking screws of the active seal with Loctite 290. Note the permitted tightening torques of the screws. ↪ Chapter 6.4 'Tightening torques' on page 26

6. ▶ Fit the flange back into its original position. Note the permitted tightening torques of the screws. ↪ Chapter 6.4 'Tightening torques' on page 26

7. ▶ Repeat steps 2 to 6 for the second flange connection.

8. ▶ Perform a functionality test. ↪ Chapter 8.2.1 'Functionality test' on page 33

9.4 Replacing the seals on the housing and gas generator holder

1. ▶ Set the slide valve to the "secured" position if it is not already in this position.

- Remove the cover of the cladding of the gas generator holder and put it aside with the screws.
- Tighten the locking bolt, hold it firmly and turn the ball valve simultaneously so that the cam switch sends a signal for the "secured" position via the switch.

2. ▶ Remove the side cladding.

3. ▶ Remove only the through bolts of the flange.



If there were shim rings on the side on which you just removed the through bolts, re-insert them in the same position when assembling the flange.

4. ▶ Remove the housing

- Loosen all screws on the upper housing.
- Remove the upper housing using the lifting eye bolts provided by screwing them onto the flange, and put it aside.

5. ➤ Remove the buffer and put it aside

6. ➤ Remove the slide blade



Remove the entire slide blade and put it aside on a clean, scratch-free surface.

7. ➤ Replace the seal on non-return valves

Repeat the following steps for all three non-return valves on the slide valve.

- Remove the face spanner under the cladding of the gas generator holder.
- Unscrew the non-return valve from the relevant side using the face spanner.
- Replace the seal or O-ring with a new one.
- Screw back the non-return valve in a flush-mounted manner so that the seal is compressed.
If the non-return valve can be screwed into the hole, counter this from outside with the throttle insert by removing the pneumatic fittings and then refitting them.
- Repeat the steps above for all three non-return valves at the slide valve.

8. ➤ Remove and dispose of the housing seal.

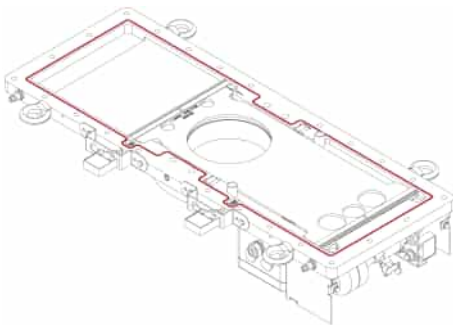

Fig. 40: Housing seal

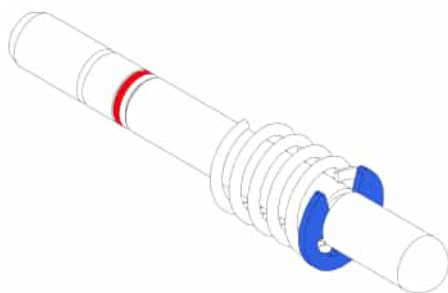

Fig. 41: Switch rod with O-ring (red) and locking ring (blue)

9. ➤ Replace the seal of the switch rod

Repeat the steps below for both switch rods.

- Remove the universal holder on which the switches for signalling the slide blade's position are fixed.
- Remove the circlip of the switch rod using a small screwdriver.
- Pull the switch rod carefully out of the housing.
- Replace the O-ring on the switch rod.
- Carry out the steps above again in reverse order and re-assemble the switch rod correctly.
- Repeat the steps above for the second switch rod.

10. ➤ Clean both halves of the housing with a cloth moistened with soapy water and then dry them.

11. ➤ Insert the new, clean housing seal.

Inspection of RSV-D

Replacing the locking screw seal

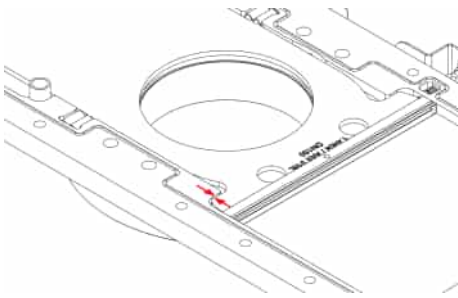

Fig. 42: Correctly inserted slide blade

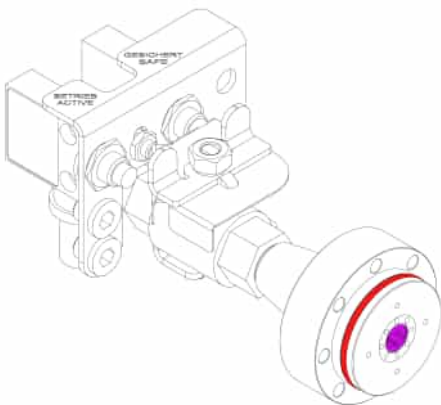

Fig. 43: Seal for the gas generator holder

12. ▶ Reinsert the slide blade correctly (the two engraved arrow heads must point at each other).
13. ▶ Re-assemble the housing and screw it together properly. ↪ Chapter 6.4 'Tightening torques' on page 26
14. ▶ Insert the buffers properly from outside. See also ↪ Chapter 9.1 'Gas generator replacement' on page 37.

15. ▶ Replace the seal for the gas generator holder
Follow points 1 to 4 to replace the seal of the gas generator holder. Replace the gas generator. ↪ Chapter 9.1 'Gas generator replacement' on page 37
16. ▶ Replace the seal. Plug the ignition cable(s) back in so that it locks in place twice. Then fit the cap of the gas generator holder and fix it again with its hexagon screws. After assembly, attach the new hologram sticker in the original place. Follow points 10 to 12. Replace the gas generator holder. ↪ Chapter 9.1 'Gas generator replacement' on page 37

9.5 Replacing the locking screw seal

1. ▶ Set the slide valve to the "secured" position if it is not already in this position.
 - Remove the cover of the cladding of the gas generator holder and put it aside with the screws.
 - Tighten the locking bolt, hold it firmly and turn the ball valve simultaneously so that the cam switch sends a signal for the "secured" position via the switch.

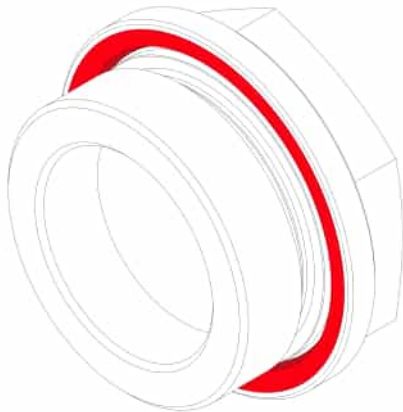

Fig. 44: Seal for buffer locking screw

2. ➤ Remove the locking screws
 - Remove both the locking screws on the upper housing and remove the O-rings.
 - Fit new O-rings in the places provided for them.
 - Re-tighten the locking screws on the upper housing firmly.
3. ➤ Move the slide valve into the “active” position
Put the slide valve or ball valve back in the “active” position.
4. ➤ Fit the cover of the gas generator holder back on.
⇒ **The slide valve is ready for operation again.**

9.6 Replacing the slide blade

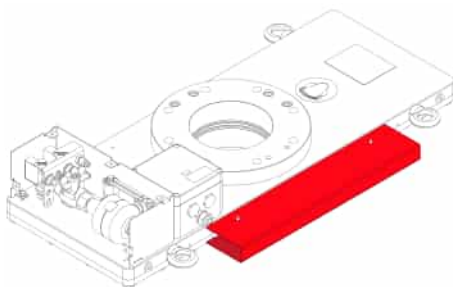

Fig. 45: Side cladding of RSV-D and -G

1. ➤ Set the slide valve to the “secured” position if it is not already in this position.
 - Remove the cover of the cladding of the gas generator holder and put it aside with the screws.
 - Tighten the locking bolt, hold it firmly and turn the ball valve simultaneously so that the cam switch sends a signal for the “secured” position via the switch.
2. ➤ Remove the side cladding.
3. ➤ Remove only the through bolts of the flange.

i *If there were shim rings on the side on which you just removed the through bolts, re-insert them in the same position when assembling the flange.*
4. ➤ Remove the housing
 - Loosen all screws on the upper housing.
 - Remove the upper housing using the lifting eye bolts provided by screwing them onto the flange, and put it aside.
5. ➤ Remove the buffer and put it to one side.
6. ➤ Remove the slide blade
Remove the entire slide blade and the ball bearings. Dispose of them.
7. ➤ Clean both halves of the housing with a cloth moistened with soapy water and then dry them.

Inspection of RSV-D

Replacing the slide blade

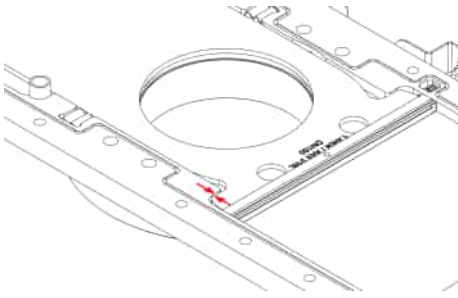

Fig. 46: Correctly inserted slide blade

8. ▶ Replace the slide blade

- Now place the new slide blade completely into one half of the housing.
- Check whether the slide blade is inserted correctly and can be moved by hand past the newly inserted ball bearings to the positions “open” and “closed”.



The slide blade is inserted correctly if the arrow heads are aligned against each other (arrow pointing at arrow).

(Slide blade of RSV-G/RSV-P nominal width = faceted, RSV-D nominal width not faceted)

10. ▶ Assemble the halves of the housing

In order to assemble the halves of the housing, repeat steps 2 to 5 in reverse order.

11. ▶ Check the gap dimensions

Check the gap between the slide blade and active seal.



Gap dimensions

The following gap dimensions are permissible:

- Good: $< 0.05 \text{ mm}$
- Bad: $\geq 0.05 \text{ mm}$

If the maximum permissible gap dimensions are exceeded, the active seals must be replaced and the flanges must be adjusted. ↪ [Chapter 9.3 'Replace the active seals' on page 43](#)

12. ▶ Move the slide valve into the “active” position

Put the slide valve or ball valve back in the “active” position.

13. ▶ Fit the cover of the gas generator holder back on.

⇒ **The slide valve is ready for operation again.**

10 Commissioning RSV-G



NOTICE!

Please note the chapter [Chapter 10.2 'Commissioning for the inliner version'](#) on page 52 in relation to the inliner version of an RSV.

10.1 Commissioning

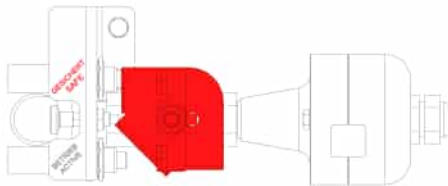

Fig. 47: Gas generator holder in "secured" position

1. ➤ Set the slide valve to the "secured" position if it is not already in this position.
 - Remove the cover of the cladding of the gas generator holder and put it aside with the screws.
 - Tighten the locking bolt, hold it firmly and turn the ball valve simultaneously so that the cam switch sends a signal for the "secured" position via the switch.
- ⇒ The explosion protection slide valve is now secured and work can be carried out on it.



All explosion protection slide valves are delivered in the "secured" position for safety reasons.

2. ➤ Exchange the locking screws for the plug nipple included in the delivery:
 - Remove both locking screws.
 - Screw the locking screws at the place provided for them (on the switch for the "secured" position).
3. ➤ Wire the slide valve via the junction box to the controller according to the electric diagram provided.
4. ➤ Remove the electric bridge according to the electric diagram.
5. ➤ Perform the functionality test according to the "Functionality test" guide.
6. ➤ The slide valve is now ready for use.

10.1.1 Functionality test RSV-G/RSV-P



NOTICE!

With regard to the inliner version of an RSV, it is not possible to carry out a complete functionality test. Please give due consideration to the chapter [Chapter 10.2.1 'Functionality test RSV-G/RSV-P for the inliner version'](#) on page 53 in this regard.

Commissioning RSV-G

Commissioning > Functionality test RSV-G/RSV-P

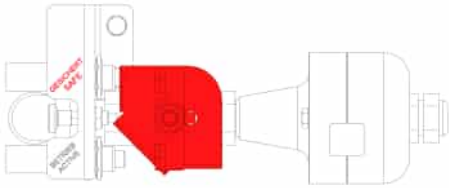

Fig. 48: Gas generator holder in "secured" position

1. ➤ Set the slide valve to the "secured" position if it is not already in this position.

- Remove the cover of the cladding of the gas generator holder and put it aside with the screws.
- Tighten the locking bolt, hold it firmly and turn the ball valve simultaneously so that the cam switch sends a signal for the "secured" position via the switch.
If not, check the switches, cables and connections for damage and replace them if need be.

⇒ The explosion protection slide valve is now secured and work can be carried out on it.

2. ➤ Remove the guard plate at the side, which protects the switches from damage, by loosening the two hexagon screws. Put the screws and guard plate aside.

3. ➤ Pneumatically actuate the slide valve.

The following statements describe the pneumatic actuation of a slide valve in its basic design:

- Connect a self-locking coupling to the plug nipple where "ZU/CLOSE" is engraved on the housing. Use a pressure controller here, if available.
- Check whether the slide blade can be moved with 6 bar or if it can be moved to the closed position. If the slide valve cannot be closed with 6 bar, it must be inspected.
- In the closed position, check whether your controller is receiving a signal.
If not, check the switches, cables and connections for damage and replace them if need be.
- Now connect a self-locking coupling to the plug nipple where "AUF/OPEN" is engraved on the housing. Please refer to the information section below for details of the dwell time in the end positions. Then open the slide valve again.
- In the open position, check whether your controller is receiving a signal.
If not, check the switches, cables and connections for damage and replace them if need be.

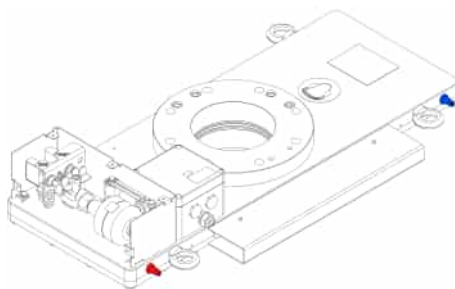

Fig. 49: RSV with plug nipple for OPEN (blue) and CLOSED (red)



Activation pressure

The pneumatic pressure for activating the slide valve must be **6 bar**. The pneumatic closing or opening time must be ≤ 6 s and should be measured using the controller.



Dwell time in position "AUF/OPEN"/ "ZU/CLOSE"

In the open and close position, please observe a dwell time of at least **1 minute**.

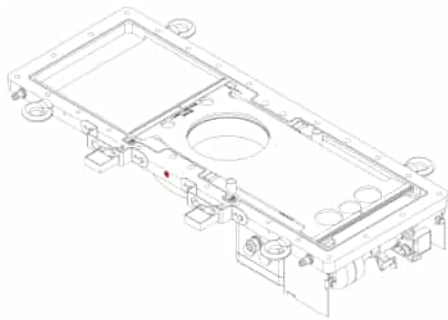

Fig. 50: Non-return valve

4. ➔ Check the non-return valves for a water leak
After pneumatic activation, check if water is leaking at the non-return valves.
If so, the slide valve and compressed air supply must be checked immediately.

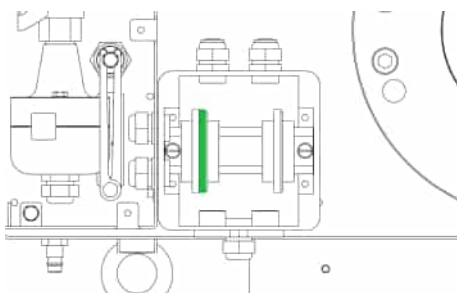

Fig. 51: PE terminal

5. ➔ Checking the earthing
Check if the slide blade is earthed by measuring the resistance from the earthing terminal in the junction box to the slide blade ($\leq 1 \text{ ohm}$).
6. ➔ Check the prescribed screw tightening torques ↪ Chapter 6.4 'Tightening torques' on page 26

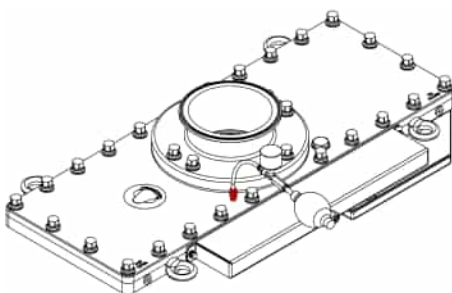

Fig. 52: Gas-tight test of RSV-G and RSV-P

7. ➔ Check the slide valve to see if it is gas-tight using the hand pump included in the delivery.
 - Remove the cap for the threaded nipple and fit the hand pump to it.
 - Create excess pressure of 0.2 bar by pumping.



RSV-G and RSV-P

Test pressure 0.2 bar

Tightness is fulfilled if the drop in pressure is $\leq 0.1 \text{ bar/min}$.

Tightness is **not** fulfilled if the drop in pressure is $> 0.1 \text{ bar/min}$.

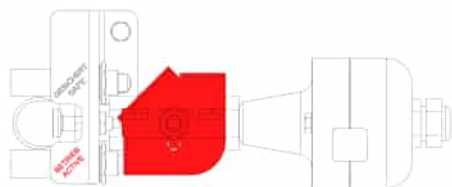

Fig. 53: "Active" position of gas generator holder

8. ➔ Put the slide valve or ball valve in the "active" position and check if the switch is sending a signal for the "active" position.
If not, check the switches, cables and connections for damage and replace them if need be.
9. ➔ Upon completion of the functionality test, the plug nipples need to be removed again and the pneumatic holes need to be sealed by means of locking screws.

Commissioning RSV-G

Commissioning for the inliner version

10. ▶ Assemble all the covers removed earlier using the screws provided for this purpose.

⇒ **If the functionality test is passed successfully, the slide valve can be put into operation.**



Sensors

The use of sensors in an outdoor explosion zone is only permitted during intrinsically safe operation.

10.2 Commissioning for the inliner version

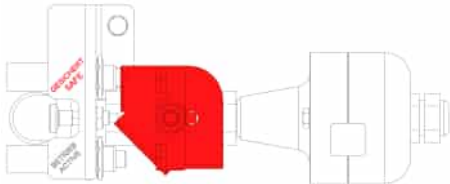

Fig. 54: Gas generator holder in "secured" position

1. ▶ Set the slide valve to the "secured" position if it is not already in this position.

- Remove the cover of the cladding of the gas generator holder and put it aside with the screws.
- Tighten the locking bolt, hold it firmly and turn the ball valve simultaneously so that the cam switch sends a signal for the "secured" position via the switch.

⇒ The explosion protection slide valve is now secured and work can be carried out on it.



All explosion protection slide valves are delivered in the "secured" position for safety reasons.

2. ▶ Wire the slide valve via the junction box to the controller according to the electric diagram provided.

3. ▶ Remove the electric bridge according to the electric diagram.

4. ▶ Perform the functionality test according to the "Functionality test for the inliner version" guide.

5. ▶ The slide valve is now ready for use.

10.2.1 Functionality test RSV-G/RSV-P for the inliner version

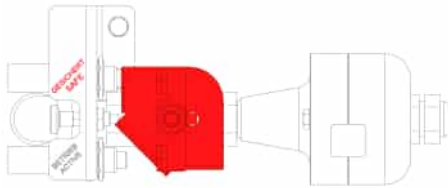

Fig. 55: Gas generator holder in "secured" position

1. ➔ Set the slide valve to the "secured" position if it is not already in this position.

- Remove the cover of the cladding of the gas generator holder and put it aside with the screws.
- Tighten the locking bolt, hold it firmly and turn the ball valve simultaneously so that the cam switch sends a signal for the "secured" position via the switch. If not, check the switches, cables and connections for damage and replace them if need be.

⇒ The explosion protection slide valve is now secured and work can be carried out on it.

2. ➔ Remove the guard plate at the side, which protects the switches from damage, by loosening the two hexagon screws. Put the screws and guard plate aside.

3. ➔ Check whether a signal is sent for the "open" position. Conversely, please check that no signal is displayed for the "closed" position.

As the explosion protection slide valve is not to be put in the "closed" position pneumatically in the inliner version, please still proceed as follows to check the switching signal for these switches:

⇒ ■ **Inductive switch:** Check the switching signal using a metal piece such as a screwdriver. See the figure below.

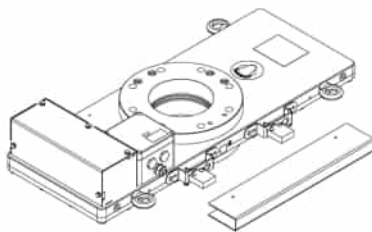

Fig. 56: Disassembly of the guard plate

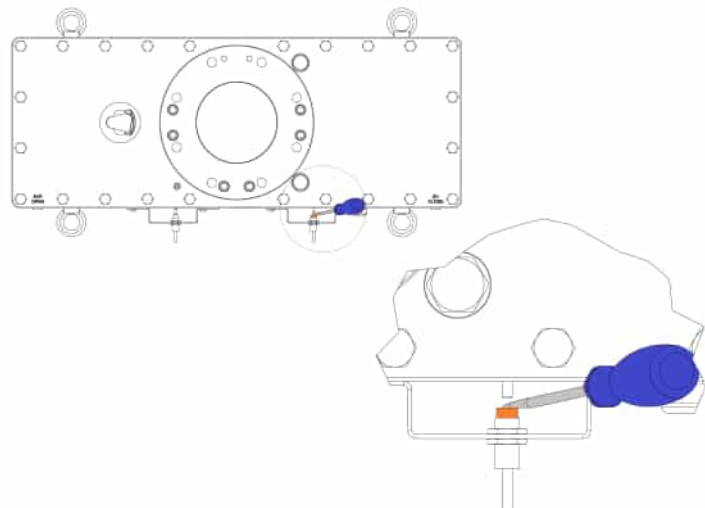

Fig. 57: Checking the switching signal

- **Mechanical switch:** You can actuate the mechanical switch by hand and then check whether a switching signal is displayed.

Commissioning RSV-G

Commissioning for the inliner version > Functionality test RSV-G/RSV-P for the inliner version

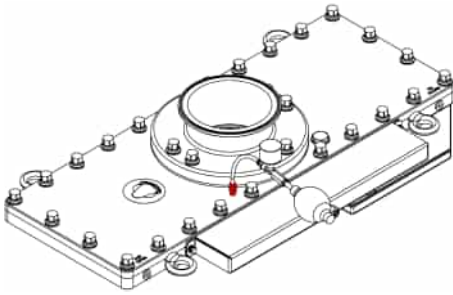

Fig. 58: Gas-tight test of RSV-G and RSV-P

4. ▶ Check the slide valve to see if it is gas-tight using the hand pump included in the delivery.
 - Remove the cap for the threaded nipple and fit the hand pump to it.
 - Create excess pressure of 0.2 bar by pumping.



RSV-G and RSV-P

Test pressure 0.2 bar

Tightness is fulfilled if the drop in pressure is ≤ 0.1 bar/min.

*Tightness is **not** fulfilled if the drop in pressure is > 0.1 bar/min.*

5. ▶ Check the prescribed screw tightening torques. ↪ *Chapter 6.4 'Tightening torques' on page 26*

6. ▶ Put the slide valve or ball valve in the "active" position and check if the switch is sending a signal for the "active" position.

If not, check the switches, cables and connections for damage and replace them if need be.

7. ▶ Assemble all the covers removed earlier using the screws provided for this purpose.

⇒ **If the functionality test is passed successfully, the slide valve can be put into operation.**



Sensors

The use of sensors in an outdoor explosion zone is only permitted during intrinsically safe operation.

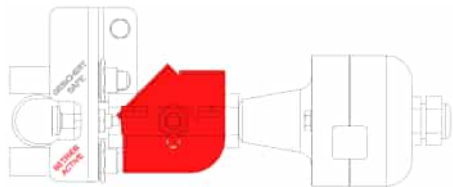

Fig. 59: "Active" position of gas generator holder

11 Maintenance of RSV-G

11.1 Maintenance



The maintenance intervals are dependent on the operating conditions of the slide valve.

*We recommend that you do not actuate the slide valve pneumatically outside the maintenance intervals, in order to prevent the ingress of dust inside the slide valve. However, please ensure that the slide valve **is pneumatically actuated at least once a year.***



WARNING!

Maintenance and inspections in Ex zones

Maintenance and inspections must not be carried out in Ex zones. If this is not possible, appropriate safety measures must be taken and suitable tools must be used.

Maintenance intervals to be observed

Interval	Maintenance work
a) 3 to 5 days after commissioning	Functionality test
b) 3 months	Functionality test, visual and wear monitoring
c) Annually or depending on process	Functionality test, visual and wear monitoring
c) Every 8 years	The gas generator must be replaced no later than after 8 years (see chapter "Gas generator").
d) Every 5 years	All seals must be replaced no later than after 5 years.



Replacing the slide blade

After 10 activations by gas generators, the entire slide blade and the spring-loaded ball bearing must be replaced.



Activation in secured position

In the event of possible activation in the "secured" position, the entire gas generator holder unit must be replaced.

11.1.1 Test process after an explosion/fire

After an explosion or fire, the device must be inspected in accordance with the MB0008 instruction manual and the following points must be checked:

Check of the housing

- Check for deformation of the housing on the outside (across the entire length of the housing)
 - Evenness ≤ 0.5 mm (DN50–DN150)
 - Evenness ≤ 0.8 mm (DN200–DN300)
 - Evenness ≤ 1.0 mm (DN400–DN500)

Check of the flange

- Check for deformation of the flange
 - The axial true running of the flange, from the bearing face to the sealing face, must be ≤ 0.05 mm.

The following parts must be replaced

- – Entire slide blade
- Screw connections
- All seals
- Springs
- Ball bearings
- Non-return valves

Measuring equipment required

- – Measuring table
- Dial gauge, 0.01 mm

Tools required

- – Feeler gauge from 0.1 mm to 1.0 mm
- Hand pump with pressure gauge
- Set of open-ended wrenches from 10 mm to 27 mm
- Set of Allen keys from 4 mm to 17 mm

11.2 Recurring maintenance

11.2.1 Functionality test RSV-G/RSV-P



NOTICE!

With regard to the inliner version of an RSV, it is not possible to carry out a complete functionality test. Please give due consideration to the chapter [Chapter 11.2.2 'Functionality test RSV-G/RSV-P for the inliner version'](#) on page 59 in this regard.

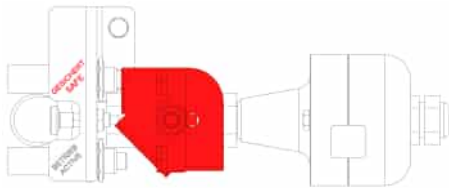

Fig. 60: Gas generator holder in "secured" position

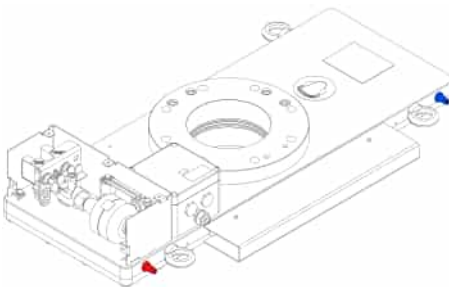

Fig. 61: RSV with plug nipple for OPEN (blue) and CLOSED (red)

1. ➔ Set the slide valve to the "secured" position if it is not already in this position.

- Remove the cover of the cladding of the gas generator holder and put it aside with the screws.
- Tighten the locking bolt, hold it firmly and turn the ball valve simultaneously so that the cam switch sends a signal for the "secured" position via the switch.
If not, check the switches, cables and connections for damage and replace them if need be.

⇒ The explosion protection slide valve is now secured and work can be carried out on it.

2. ➔ Remove the guard plate at the side, which protects the switches from damage, by loosening the two hexagon screws. Put the screws and guard plate aside.

3. ➔ Pneumatically actuate the slide valve.

The following statements describe the pneumatic actuation of a slide valve in its basic design:

- Connect a self-locking coupling to the plug nipple where "ZU/CLOSE" is engraved on the housing. Use a pressure controller here, if available.
- Check whether the slide blade can be moved with 6 bar or if it can be moved to the closed position. If the slide valve cannot be closed with 6 bar, it must be inspected.
- In the closed position, check whether your controller is receiving a signal.
If not, check the switches, cables and connections for damage and replace them if need be.
- Now connect a self-locking coupling to the plug nipple where "AUF/OPEN" is engraved on the housing. Please refer to the information section below for details of the dwell time in the end positions. Then open the slide valve again.
- In the open position, check whether your controller is receiving a signal.
If not, check the switches, cables and connections for damage and replace them if need be.



Activation pressure

The pneumatic pressure for activating the slide valve must be **6 bar**. The pneumatic closing or opening time must be ≤ 6 s and should be measured using the controller.



Dwell time in position "AUF/OPEN"/ "ZU/CLOSE"

In the open and close position, please observe a dwell time of at least **1 minute**.

Maintenance of RSV-G

Recurring maintenance > Functionality test RSV-G/RSV-P

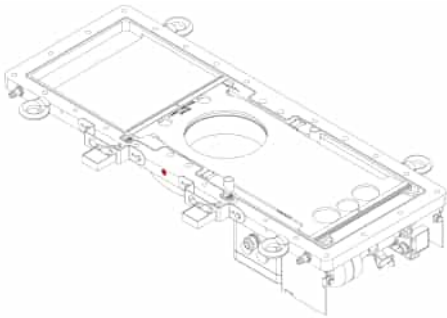

Fig. 62: Non-return valve

4. Check the non-return valves for a water leak
After pneumatic activation, check if water is leaking at the non-return valves.
If so, the slide valve and compressed air supply must be checked immediately.

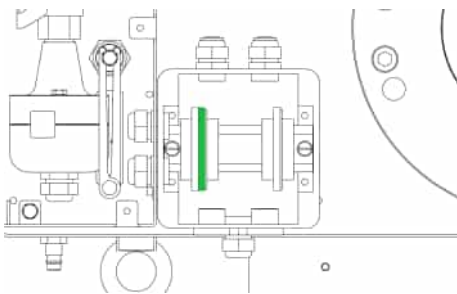

Fig. 63: PE terminal

5. Checking the earthing
Check if the slide blade is earthed by measuring the resistance from the earthing terminal in the junction box to the slide blade ($\leq 1 \text{ ohm}$).
6. Check the prescribed screw tightening torques ↪ Chapter 6.4 'Tightening torques' on page 26

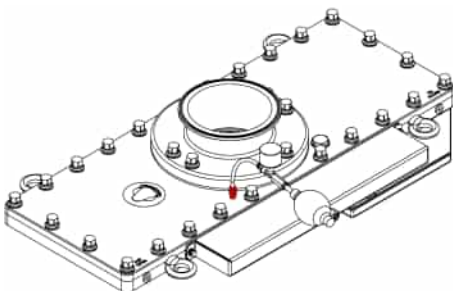

Fig. 64: Gas-tight test of RSV-G and RSV-P

7. Check the slide valve to see if it is gas-tight using the hand pump included in the delivery.
 - Remove the cap for the threaded nipple and fit the hand pump to it.
 - Create excess pressure of 0.2 bar by pumping.



RSV-G and RSV-P

Test pressure 0.2 bar

Tightness is fulfilled if the drop in pressure is $\leq 0.1 \text{ bar/min}$.

Tightness is **not** fulfilled if the drop in pressure is $> 0.1 \text{ bar/min}$.

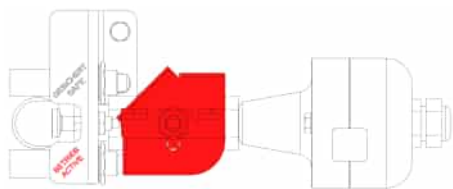

Fig. 65: "Active" position of gas generator holder

8. Put the slide valve or ball valve in the "active" position and check if the switch is sending a signal for the "active" position.
If not, check the switches, cables and connections for damage and replace them if need be.
9. Upon completion of the functionality test, the plug nipples need to be removed again and the pneumatic holes need to be sealed by means of locking screws.

10. Assemble all the covers removed earlier using the screws provided for this purpose.

⇒ **If the functionality test is passed successfully, the slide valve can be put into operation.**



Sensors

The use of sensors in an outdoor explosion zone is only permitted during intrinsically safe operation.

11.2.2 Functionality test RSV-G/RSV-P for the inliner version

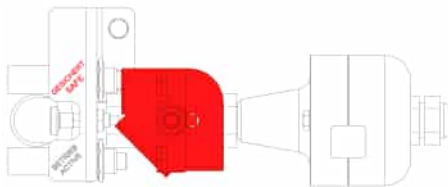

Fig. 66: Gas generator holder in "secured" position

1. Set the slide valve to the "secured" position if it is not already in this position.

- Remove the cover of the cladding of the gas generator holder and put it aside with the screws.
- Tighten the locking bolt, hold it firmly and turn the ball valve simultaneously so that the cam switch sends a signal for the "secured" position via the switch. If not, check the switches, cables and connections for damage and replace them if need be.

⇒ The explosion protection slide valve is now secured and work can be carried out on it.

2. Remove the guard plate at the side, which protects the switches from damage, by loosening the two hexagon screws. Put the screws and guard plate aside.

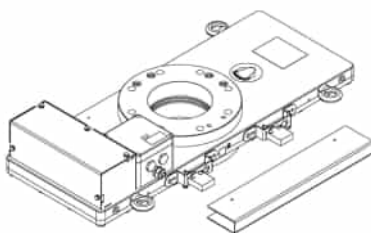

Fig. 67: Disassembly of the guard plate

Maintenance of RSV-G

Recurring maintenance > Functionality test RSV-G/RSV-P for the inliner version

3. Check whether a signal is sent for the "open" position. Conversely, please check that no signal is displayed for the "closed" position.

As the explosion protection slide valve is not to be put in the "closed" position pneumatically in the inliner version, please still proceed as follows to check the switching signal for these switches:

- ⇒ ■ **Inductive switch:** Check the switching signal using a metal piece such as a screwdriver. See the figure below.

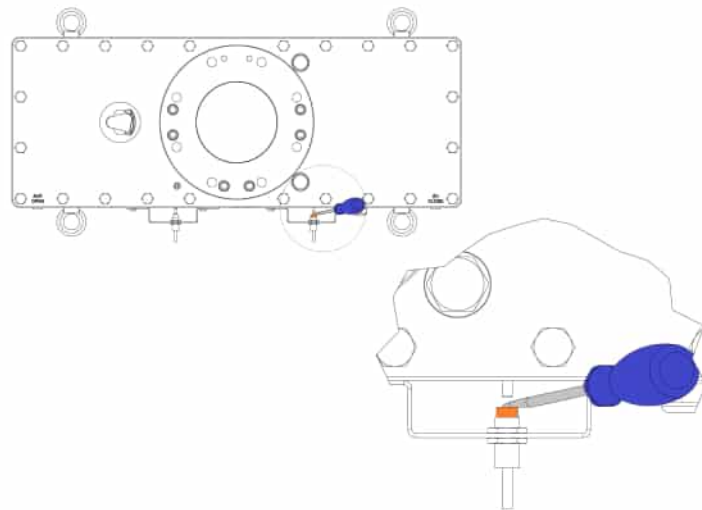

Fig. 68: Checking the switching signal

- **Mechanical switch:** You can actuate the mechanical switch by hand and then check whether a switching signal is displayed.

4. Check the slide valve to see if it is gas-tight using the hand pump included in the delivery.
 - Remove the cap for the threaded nipple and fit the hand pump to it.
 - Create excess pressure of 0.2 bar by pumping.

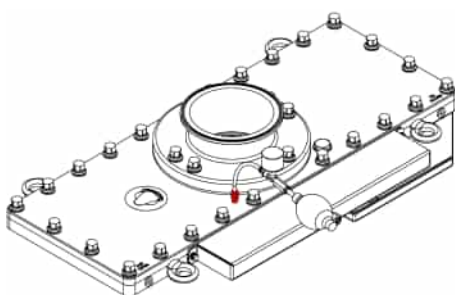

Fig. 69: Gas-tight test of RSV-G and RSV-P



RSV-G and RSV-P

Test pressure 0.2 bar

Tightness is fulfilled if the drop in pressure is ≤ 0.1 bar/min.

Tightness is **not** fulfilled if the drop in pressure is > 0.1 bar/min.

5. Check the prescribed screw tightening torques. ↪ Chapter 6.4 'Tightening torques' on page 26

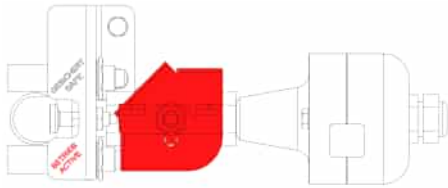

Fig. 70: "Active" position of gas generator holder

6. ➔ Put the slide valve or ball valve in the "active" position and check if the switch is sending a signal for the "active" position.

If not, check the switches, cables and connections for damage and replace them if need be.

7. ➔ Assemble all the covers removed earlier using the screws provided for this purpose.

⇒ **If the functionality test is passed successfully, the slide valve can be put into operation.**



Sensors

The use of sensors in an outdoor explosion zone is only permitted during intrinsically safe operation.

11.2.3 Visual check and wear monitoring



NOTICE!

Please give due consideration to the chapter & Chapter 11.2.4 'Visual check and wear monitoring for the inliner version' on page 62 for the inliner version of an RSV instead of this chapter.

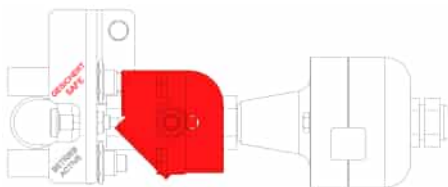

Fig. 71: Gas generator holder in "secured" position

1. ➔ Set the slide valve to the "secured" position if it is not already in this position.

- Remove the cover of the cladding of the gas generator holder and put it aside with the screws.
- Tighten the locking bolt, hold it firmly and turn the ball valve simultaneously so that the cam switch sends a signal for the "secured" position via the switch. If not, check the switches, cables and connections for damage and replace them if need be.

⇒ The explosion protection slide valve is now secured and work can be carried out on it.

2. ➔ Check the housing, passage and junction box for corrosion and mechanical damage.

3. ➔ Check for impurities and deposits

Check whether deposits are present in the area of the lead-through or flanges.

If there are, clean the passage with a cloth moistened with soapy water and then dry it.

Maintenance of RSV-G

Recurring maintenance > Visual check and wear monitoring for the inliner version

4. ▶ Check gas tightness

- Remove the cap for the threaded nipple and fit the hand pump to it.
- Create excess pressure of 0.2 bar by pumping.



RSV-G and RSV-P

Test pressure 0.2 bar

Tightness is fulfilled if the drop in pressure is ≤ 0.1 bar/min.

*Tightness **is not** fulfilled if the drop in pressure is > 0.1 bar/min.*

5. ▶ Flange seal check

Check the flange seals for visible damage.

If they are damaged, they must be replaced.

11.2.4 Visual check and wear monitoring for the inliner version

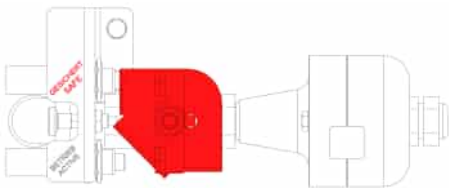

Fig. 72: Gas generator holder in "secured" position

1. ▶ Set the slide valve to the "secured" position if it is not already in this position.

- Remove the cover of the cladding of the gas generator holder and put it aside with the screws.
- Tighten the locking bolt, hold it firmly and turn the ball valve simultaneously so that the cam switch sends a signal for the "secured" position via the switch.
If not, check the switches, cables and connections for damage and replace them if need be.

⇒ The explosion protection slide valve is now secured and work can be carried out on it.

2. ▶ Check the housing and the junction box for corrosion and mechanical damage. Please also check the inliner for abrasion and mechanical damage.

3. ▶ Check for impurities and deposits

Check whether deposits are present in the area of the lead-through or flanges.

If there are, clean the passage with a cloth moistened with soapy water and then dry it.

4. ▶ Check gas tightness

- Remove the cap for the threaded nipple and fit the hand pump to it.
- Create excess pressure of 0.2 bar by pumping.



RSV-G and RSV-P

Test pressure 0.2 bar

Tightness is fulfilled if the drop in pressure is ≤ 0.1 bar/min.

*Tightness is **not** fulfilled if the drop in pressure is > 0.1 bar/min.*

5. ▶ Flange seal check

Check the flange seals for visible damage.

If they are damaged, they must be replaced.

12 Inspection of RSV-G



NOTICE!

Explosive event

The slide valve must be **inspected after every explosion**, when it shows **signs of wear** or **after 5 years**.

Otherwise the function of the slide valve is not ensured.



WARNING!

Maintenance and inspections in Ex zones

Maintenance and inspections must not be carried out in Ex zones. If this is not possible, appropriate safety measures must be taken and suitable tools must be used.

12.1 Gas generator replacement

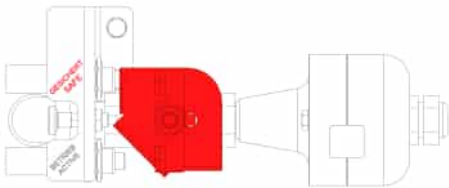

Fig. 73: Gas generator holder in "secured" position

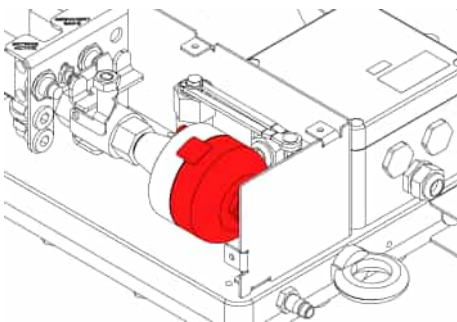
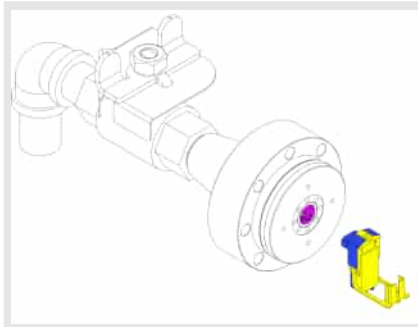

Fig. 74: Cap for gas generator holder

1. ➤ Set the slide valve to the "secured" position if it is not already in this position.
 - Remove the cover of the cladding of the gas generator holder and put it aside with the screws.
 - Tighten the locking bolt, hold it firmly and turn the ball valve simultaneously so that the cam switch sends a signal for the "secured" position via the switch.
2. ➤ Remove the hologram sticker between the cap and gas generator holder.
3. ➤ Remove the hexagon screws holding the cap in place. Remove the cap.

4. ➔ Unplug the ignition cable

Remove the plug-in connector for the gas generator by loosening the fuse and pulling out the plug-in connector.



Plug for RSV DN50–DN150 unplugged

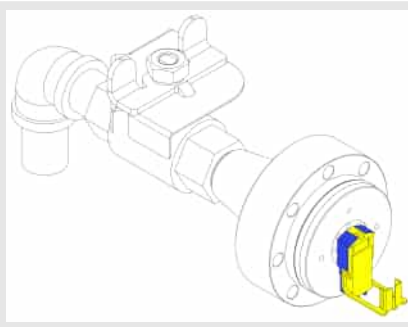

Plug for RSV DN50–DN150 **single-plugged**

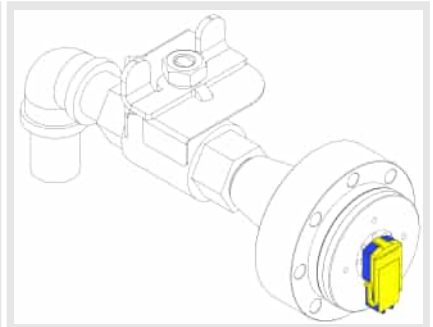

Plug for RSV DN50–DN150 **double-plugged**

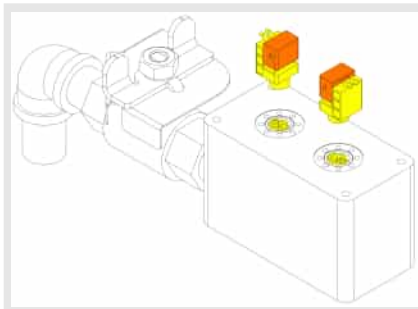

Plug for RSV DN200–DN400 unplugged

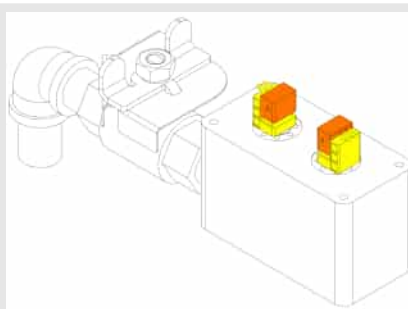

Plug for RSV DN200–DN400 **single-plugged**

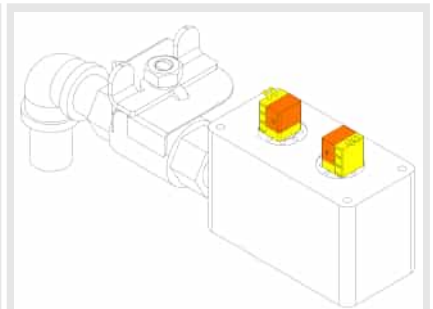

Plug for RSV DN200–DN400 **double-plugged**

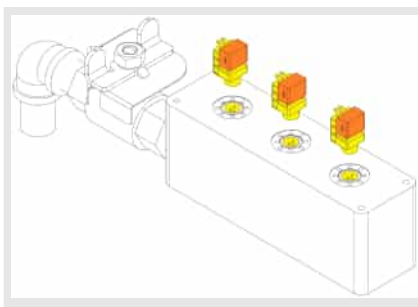

Plug for RSV DN500 unplugged

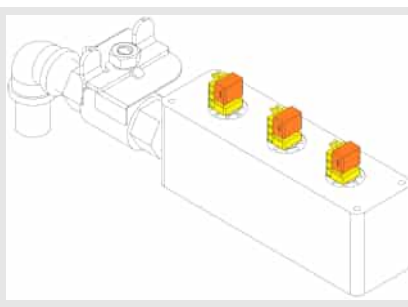

Plug for RSV DN500 **single-plugged**

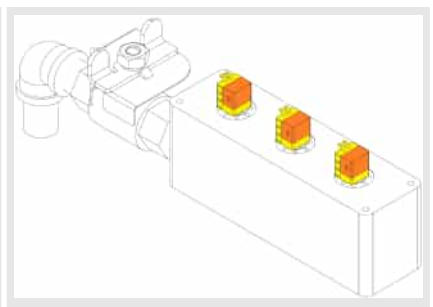

Plug for RSV DN500 **double-plugged**

Inspection of RSV-G

Gas generator replacement

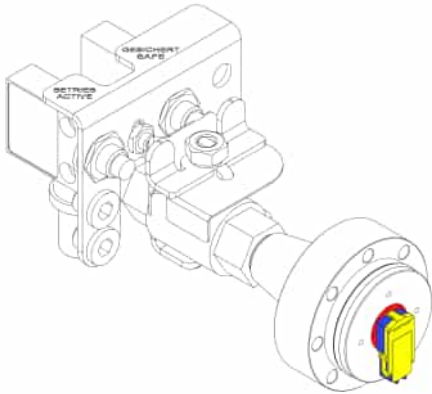

Fig. 75: Spark plug (yellow, blue) and locking screw (red)

5. ▶ Remove the gas generator
 - Take the face spanner included in the delivery out of its holder.
 - Loosen the locking screw from the gas generator holder and remove it.
 - Remove the activated gas generator with pliers and dispose of it. ↪ *Chapter 16 'Disposing of RSV-D / RSV-G and RSV-P' on page 111*
6. ▶ Remove gas generator residue
 - Move the ball valve into the “active” position.
 - Apply 6 bar compressed air to the slide valve in this position via the pneumatic connection “ZU/CLOSE” for 15 seconds.
 - ⇒ Any gas generator residue must now be blown out from the gas generator holder and housing.
7. ▶ Before continuing with the work, move the ball valve or slide valve back into the “secured” position.

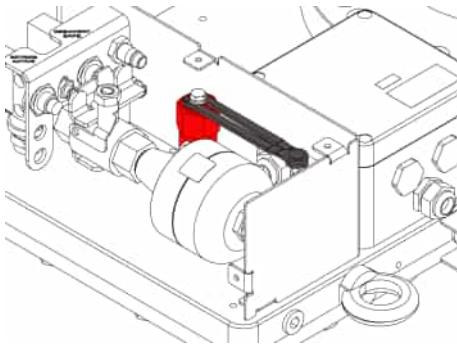
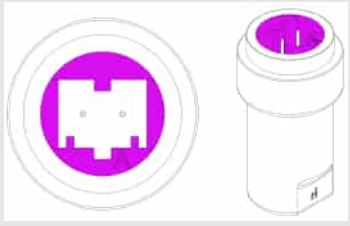
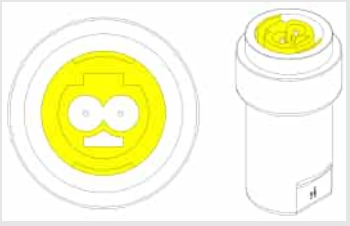

Fig. 76: Spare gas generator holder (red) and face pin wrench

8. Insert the gas generator

- Remove the new gas generator(s) (depending on their nominal width) from the spare gas generator holder by unscrewing it/them.
- Remove the new gas generators, buffers and hologram stickers.
- Apply a little high-temperature grease (e.g. Klüber Wolf-racoat C) to the gas generator.
Insert the new gas generator(s) (depending on their nominal width) and re-tighten with the locking screw.
- Plug the ignition cable(s) back in so that it locks in place twice.
- **Place the cap of the generator on it and fix it again with its hexagon screws.**
- Stick one of the new hologram labels on the cap and gas generator holder.
- Screw back the empty spare gas generator holder and face spanner into the positions provided for this.

	
Gas generator charge 0.8 g DN50–DN150 Article no. 010138	Gas generator charge 1.3 g DN200–DN500 Article no. 126323



Reactivation kit

Order new gas generators, buffers and hologram stickers immediately. For this, use the MF0006DE form, which can be downloaded at www.service.rico.ch or <http://www.rico.ch/de/download>.

Ensure that the new gas generators and buffers reach the spare gas generator holders provided for this right away and are thus always available.



CAUTION!

Do not move the ball valve or slide valve into the “active” position yet.

Inspection of RSV-G

Replacing the gas generator holder

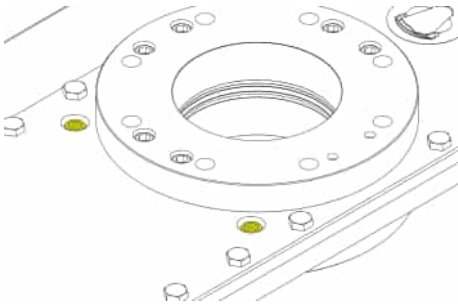

Fig. 77: Buffer without locking keys

9. ▶ Replace the buffers

- Remove the locking screw on the upper housing and put it aside.
- Move the slide valve or slide blade to the “open” position according to the functional test. ↪ *Chapter 8.2.1 ‘Functionality test’ on page 33*
If this is not successful, extend the buffers using a large screwdriver, so that the slide valve can be actuated or opened pneumatically.
- Remove the destroyed buffers using pliers and/or a screwdriver.
- Insert the new buffers included in the delivery.
- Re-tighten the locking screws firmly.

10. ▶ Change hologram stickers on the housing

- Remove the lateral guard plate.
- Remove the existing hologram sticker and replace it with the new one so that it has the same number as the sticker on the gas generator holder.
- Fit the lateral guard plate back.

11. ▶ Move the slide valve into the “active” position

Move the slide valve or ball valve back into the “active” position.

12. ▶ Fit the cover of the gas generator holder.

⇒ **The slide valve is ready for operation again.**

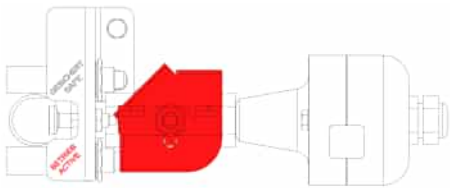

Fig. 78: “Active” position of gas generator holder

12.2 Replacing the gas generator holder

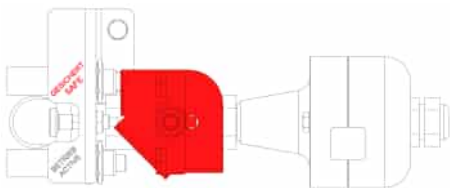

Fig. 79: Gas generator holder in “secured” position

1. ▶ Set the slide valve to the “secured” position if it is not already in this position.

- Remove the cover of the cladding of the gas generator holder and put it aside with the screws.
- Tighten the locking bolt, hold it firmly and turn the ball valve simultaneously so that the cam switch sends a signal for the “secured” position via the switch.

2. ▶ Remove the hologram sticker between the cap and gas generator holder.

3. ▶ Remove the hexagon screws holding the cap in place. Remove the cap.

4. ▶ Unplug the ignition cable

Remove the plug-in connector for the gas generator by loosening the safeguard and pulling out the plug-in connector.

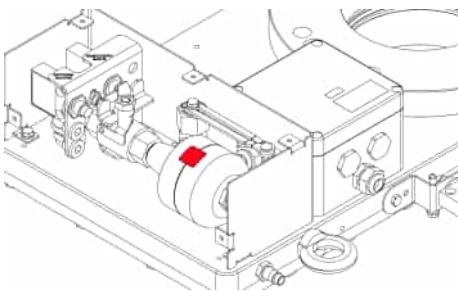

Fig. 80: Hologram stickers

5. ➤ Remove the gas generator

- Take the face spanner included in the delivery out of its holder.
- Loosen the locking screw from the gas generator holder and remove it.
- Remove the activated gas generator with pliers and dispose of it. ⚠ *'Ignited gas generators' on page 111*

6. ➤ Remove the junction box

- Open the junction box by loosening the four screws.
- Remove the junction box by loosening the four cylinder head screws inside the junction box.



There is no need to interfere with the cables.

- Remove the entire cladding of the gas generator holder.
- Remove the spare gas generator holder.
- Remove the holder of both switches for the position "active" and "secured", and the earthing cable.

⇒ The gas generator holder is now free.

7. ➤ Remove the gas generator holder

- Heat the fitting with a hot air dryer so that it can be "unlocked" and loosened.
- Turn the gas generator holder including the threaded fitting until it can be removed, and dispose of the gas generator holder.

8. ➤ Via the pneumatic connection "ZU/CLOSE", apply 6 bar compressed air to the slide valve for 15 seconds in this position. This will blow out any residue from the gas generator.

9. ➤ Coat the thread fitting with Loctite 577 thread sealant.

10. ➤ Now, screw on the new gas generator holder so that the axis of the ball valve is parallel to the housing.

Inspection of RSV-G

Replacing the FEP-O-seals

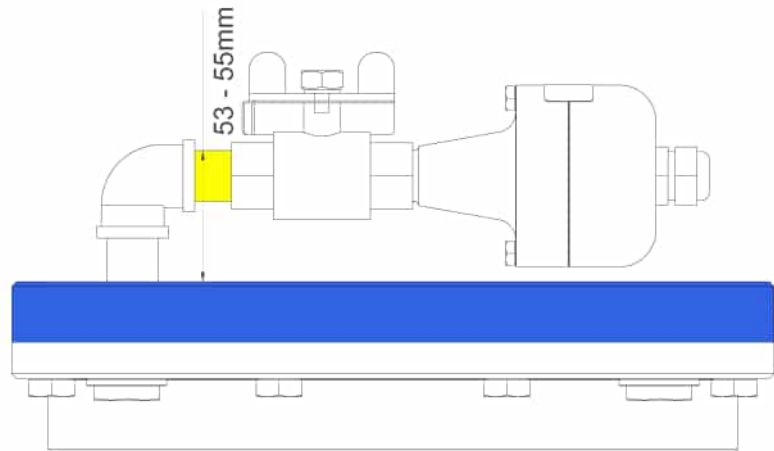

Fig. 81: Installation height, RSV gas generator holder

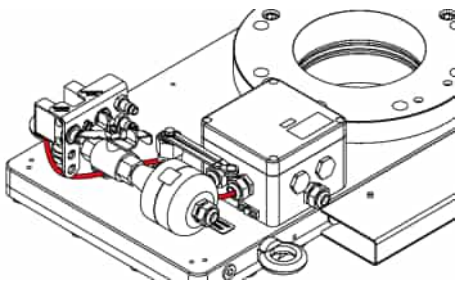

Fig. 82: Route of switch cable

11. ▶ Install the universal holder, cladding, junction box and spare gas generator holder.
Install the switch holder with the earthing. Ensure that the cable between the junction box and switch goes under the gas generator holder and switch holder.
12. ▶ Now, move the ball valve or **slide valve back into the “secured” position.**
13. ▶ Assemble or fix the cladding of the gas generator holder again.
14. ▶ Fit and connect the junction box back correctly.
15. ▶ Continue according to [Chapter 12.1 ‘Gas generator replacement’](#) on page 64, point 8 “Inserting the gas generator”.

12.3 Replacing the FEP-O-seals

1. ▶ Set the slide valve to the “secured” position if it is not already in this position.
 - Remove the cover of the cladding of the gas generator holder and put it aside with the screws.
 - Tighten the locking bolt, hold it firmly and turn the ball valve simultaneously so that the cam switch sends a signal for the “secured” position via the switch.

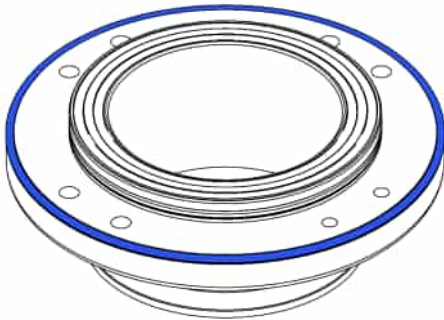

Fig. 83: RSV-P outer flange seal, for pharmaceutical applications

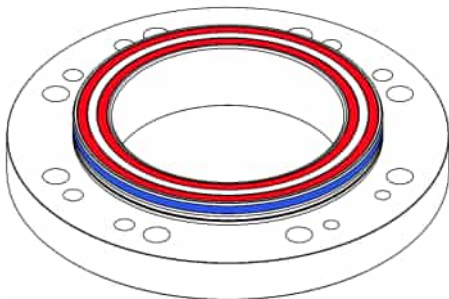

Fig. 84: FEP-O-seal (red) and outer flange seal (blue) of RSV-G

2. Removing the flange connection

First remove a flange, change the FEP-O-seals and repeat the following steps for the other side. For the RSV-P design, the outer flange seal for pharmaceutical applications must be replaced.

- Loosen and remove all screws on the respective flange.
- On the other side, loosen and remove only those screws that have through-holes.



If there were shim rings on the side on which you just removed the flange, re-insert them in the same position when assembling the flange.

3. On the flange that has been removed, remove the FEB-O-seal and the outer flange seal or, in the case of RSV-P, even the flange seal for pharmaceutical applications.
4. Clean the flange using a cloth moistened with soapy water.
5. Fit the new seals in reverse order.
6. Fit the flange back into its original position. Note the permitted tightening torques of the screws. ↪ *Chapter 6.4 'Tightening torques' on page 26*
7. Repeat steps 2 to 6 for the second flange connection.
8. Perform a functionality test.

12.3.1 Replacing the inliner seal

1. Set the slide valve to the "secured" position if it is not already in this position.
 - Remove the cover of the cladding of the gas generator holder and put it aside with the screws.
 - Tighten the locking bolt, hold it firmly and turn the ball valve simultaneously so that the cam switch sends a signal for the "secured" position via the switch.

2. Remove the flange connection

First remove one flange.

- Loosen and remove all screws on the respective flange.
- On the other side, loosen and remove only those screws that have through-holes.



If there were shim rings on the side on which you just removed the flange, re-insert them in the same position when assembling the flange.

3. Clean the flange using a cloth moistened with soapy water.

Inspection of RSV-G

Replacing the FEP-O-seals > Replacing the inliner seal

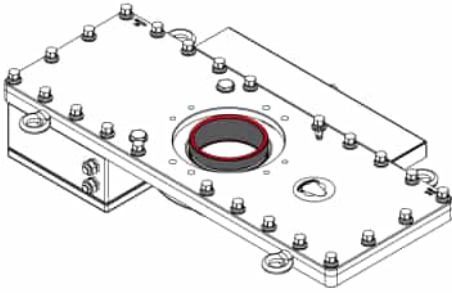

Fig. 85: PTFE inliner with O-ring

4. ➤ Remove the PTFE inliner by manually pulling it out of the bore carefully.
5. ➤ Remove the inliner seals and place the new seals properly in the correct positions.
6. ➤ Fit the flange back into its original position. Note the permitted tightening torques of the screws. ↪ Chapter 6.4 'Tightening torques' on page 26
7. ➤ Check gas tightness
 - Remove the threaded nipple and fit the hand pump on the plug
 - Create excess pressure of 0.2 bar by pumping



RSV-G and RSV-P

Test pressure 0.2 bar

Tightness is fulfilled if the drop in pressure is ≤ 0.1 bar/min.

Tightness **is not** fulfilled if the drop in pressure is > 0.1 bar/min.

If the maximum permissible drop in pressure is not reached, the FEB-O-seals must be replaced and the flanges must be adjusted. ↪ Chapter 12.3 'Replacing the FEP-O-seals' on page 70

8. ➤



NOTICE!

Do not perform a functionality test yet under any circumstances.



Commissioning

- Move the pneumatic function control to "AUF/OPEN" and "ZU/CLOSE". It is not possible to test the inliner version when it is installed.
- The inliner version may only be connected when the pneumatic connection is set to "AUF/OPEN" and actuated for the functionality test.

9. ➤ Move the slide valve into the "active" position
Put the slide valve or ball valve back in the "active" position.
10. ➤ Fit the cover of the gas generator holder back on.
⇒ **The slide valve is ready for operation again.**

Replacing the PTFE inliner after a release

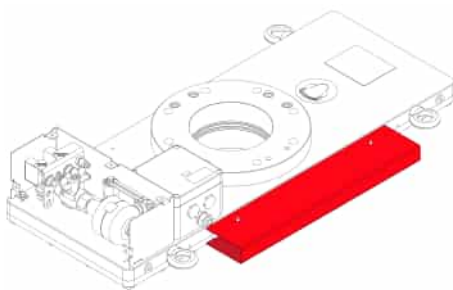

Fig. 86: Side cladding of RSV-D and -G

1. ➤ Set the slide valve to the “secured” position if it is not already in this position.
 - Remove the cover of the cladding of the gas generator holder and put it aside with the screws.
 - Tighten the locking bolt, hold it firmly and turn the ball valve simultaneously so that the cam switch sends a signal for the “secured” position via the switch.
2. ➤ Remove the side cladding. In the case of RSV-P, also remove the deaerator.
3. ➤ Remove the flange
 - Loosen and remove all screws on the respective flange.
 - On the other side, loosen and remove only those screws that have through-holes.



If there were shim rings on the side on which you just removed the through bolts, re-insert them in the same position when assembling the flange.

4. ➤ Remove the housing
 - Loosen all screws on the upper housing.
 - Remove the upper half of the housing using the lifting eye bolts provided by screwing them onto the flange, and put it aside.
5. ➤ Remove and dispose of the PTFE inliner and its residues.
6. ➤ Remove the buffer.
7. ➤ Remove the slide blade



Remove the entire slide blade and put it aside on a clean, scratch-free surface.



Fig. 87: Correctly inserted slide blade

8. ➤ Clean both halves of the housing with a cloth moistened with soapy water and then dry them.
9. ➤
 - Reinsert the slide blade correctly (the two engraved arrow heads must point at each other).
 - Check whether the slide blade is inserted correctly and can be moved by hand past the ball bearings to the positions “open” and “close”.
10. ➤ Insert the PTFE inliner
 - Remove the inliner seals and place the new seals in the correct positions in the flange groove.
 - Place the new PTFE inliner in the place provided for it and ensure that the seal sits properly on the PTFE inliner.

Inspection of RSV-G

Replacing the seals on the housing and gas generator holder

11. ▶ Assemble the halves of the housing

In order to assemble the halves of the housing, repeat steps 2 to 5 in reverse order.

12. ▶ Check gas tightness

- Remove the threaded nipple and fit the hand pump on the plug
- Create excess pressure of 0.2 bar by pumping



RSV-G and RSV-P

Test pressure 0.2 bar

Tightness is fulfilled if the drop in pressure is ≤ 0.1 bar/min.

*Tightness **is not** fulfilled if the drop in pressure is > 0.1 bar/min.*

If the maximum permissible drop in pressure is not reached, the FEB-O-seals must be replaced and the flanges must be adjusted. ↪ *Chapter 12.3 'Replacing the FEB-O-seals' on page 70*

13. ▶



NOTICE!

Do not perform a functionality test yet under any circumstances.

14. ▶ Gas generator replacement

Follow the instructions in Chapter "Replacing the gas generator". ↪ *Chapter 12.1 'Gas generator replacement' on page 64*

15. ▶ Move the slide valve into the "active" position

Put the slide valve or ball valve back in the "active" position.

16. ▶ Fit the cover of the gas generator holder back on.

⇒ **The slide valve is ready for operation again.**

12.4 Replacing the seals on the housing and gas generator holder

1. ▶ Set the slide valve to the "secured" position if it is not already in this position.

- Remove the cover of the cladding of the gas generator holder and put it aside with the screws.
- Tighten the locking bolt, hold it firmly and turn the ball valve simultaneously so that the cam switch sends a signal for the "secured" position via the switch.

2. ▶ Remove the side cladding.

3. ➤ Remove only the through bolts of the flange.



If there were shim rings on the side on which you just removed the through bolts, re-insert them in the same position when assembling the flange.

4. ➤ Remove the housing
- Loosen all screws on the upper housing.
 - Remove the upper housing using the lifting eye bolts provided by screwing them onto the flange, and put it aside.
5. ➤ Remove the buffer and put it aside
6. ➤ Remove the slide blade



Remove the entire slide blade and put it aside on a clean, scratch-free surface.

7. ➤ Replace the seal on non-return valves

Repeat the following steps for all three non-return valves on the slide valve.

- Remove the face spanner under the cladding of the gas generator holder.
- Unscrew the non-return valve from the relevant side using the face spanner.
- Replace the seal or O-ring with a new one.
- Screw back the non-return valve in a flush-mounted manner so that the seal is compressed.
If the non-return valve can be screwed into the hole, counter this from outside with the throttle insert by removing the pneumatic fittings and then refitting them.
- Repeat the steps above for all three non-return valves at the slide valve.

8. ➤ Remove and dispose of the housing seal.

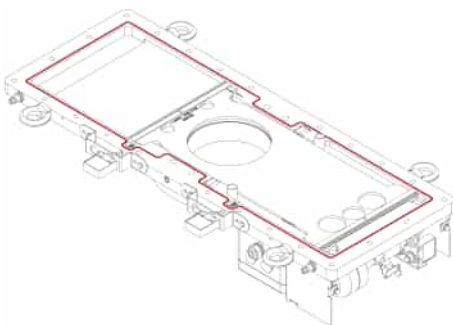

Fig. 88: Housing seal

Inspection of RSV-G

Replacing the locking screw seal

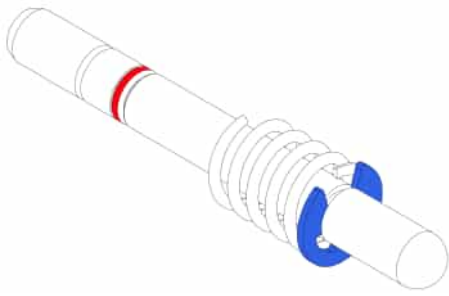

Fig. 89: Switch rod with O-ring (red) and locking ring (blue)

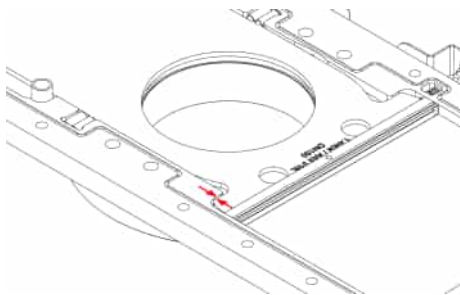

Fig. 90: Correctly inserted slide blade

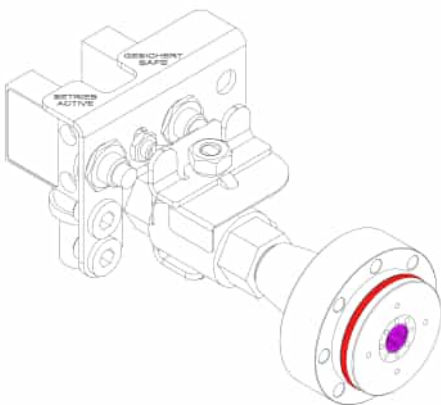

Fig. 91: Seal for the gas generator holder

9. ▶ Replace the seal of the switch rod

Repeat the steps below for both switch rods.

- Remove the universal holder on which the switches for signalling the slide blade's position are fixed.
- Remove the circlip of the switch rod using a small screwdriver.
- Pull the switch rod carefully out of the housing.
- Replace the O-ring on the switch rod.
- Carry out the steps above again in reverse order and re-assemble the switch rod correctly.
- Repeat the steps above for the second switch rod.

10. ▶ Clean both halves of the housing with a cloth moistened with soapy water and then dry them.

11. ▶ Insert the new, clean housing seal.

12. ▶ Reinsert the slide blade correctly (the two engraved arrow heads must point at each other).

13. ▶ Re-assemble the housing and screw it together properly. ↪ *Chapter 6.4 'Tightening torques' on page 26*

14. ▶ Insert the buffers properly from outside. See also ↪ *Chapter 12.1 'Gas generator replacement' on page 64.*

15. ▶ Replace the seal for the gas generator holder

Follow points 1 to 4 to replace the seal of the gas generator holder. Replace the gas generator. ↪ *Chapter 12.1 'Gas generator replacement' on page 64*

16. ▶ Replace the seal. Plug the ignition cable(s) back in so that it locks in place twice. Then fit the cap of the gas generator holder and fix it again with its hexagon screws. After assembly, attach the new hologram sticker in the original place. Follow points 10 to 12. Replace the gas generator holder. ↪ *Chapter 12.1 'Gas generator replacement' on page 64*

12.5 Replacing the locking screw seal

1. ▶ Set the slide valve to the "secured" position if it is not already in this position.

- Remove the cover of the cladding of the gas generator holder and put it aside with the screws.
- Tighten the locking bolt, hold it firmly and turn the ball valve simultaneously so that the cam switch sends a signal for the "secured" position via the switch.

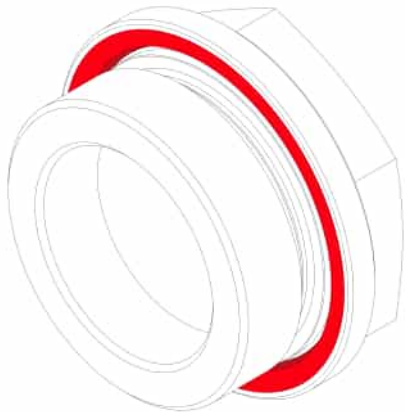

Fig. 92: Seal for buffer locking screw

2. ➤ Remove the locking screws
 - Remove both the locking screws on the upper housing and remove the O-rings.
 - Fit new O-rings in the places provided for them.
 - Re-tighten the locking screws on the upper housing firmly.
3. ➤ Move the slide valve into the “active” position
Put the slide valve or ball valve back in the “active” position.
4. ➤ Fit the cover of the gas generator holder back on.
⇒ **The slide valve is ready for operation again.**

12.6 Replacing the slide blade

1. ➤ Set the slide valve to the “secured” position if it is not already in this position.
 - Remove the cover of the cladding of the gas generator holder and put it aside with the screws.
 - Tighten the locking bolt, hold it firmly and turn the ball valve simultaneously so that the cam switch sends a signal for the “secured” position via the switch.
2. ➤ Remove the side cladding.
3. ➤ Remove only the through bolts of the flange.



If there were shim rings on the side on which you just removed the through bolts, re-insert them in the same position when assembling the flange.

4. ➤ Remove the housing
 - Loosen all screws on the upper housing.
 - Remove the upper half of the housing using the lifting eye bolts provided by screwing them onto the flange, and put it aside.
5. ➤ Remove the buffer and put it to one side.
6. ➤ Remove the slide blade
Remove the entire slide blade and the ball bearings. Dispose of them.
7. ➤ Clean both halves of the housing with a cloth moistened with soapy water and then dry them.

Inspection of RSV-G

Replacing the slide blade

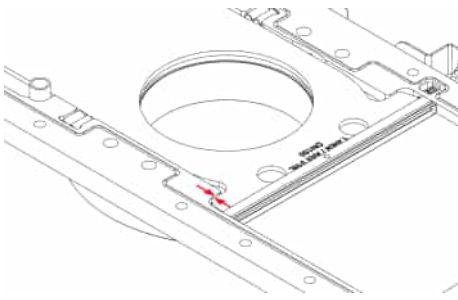

Fig. 93: Correctly inserted slide blade

8. ▶ Replacing the slide blade

- Now place the new slide blade completely into one half of the housing.
- Check whether the slide blade is inserted correctly and can be moved by hand past the newly inserted ball bearings to the positions “open” and “closed”.



The slide blade is inserted correctly if the arrow heads are aligned against each other (arrow pointing at arrow).

(Slide blade of RSV-G/RSV-P nominal width = faceted, RSV-D nominal width not faceted)

10. ▶ Assemble the halves of the housing

In order to assemble the halves of the housing, repeat steps 2 to 5 in reverse order.

11. ▶ Check gas tightness

- Remove the threaded nipple and fit the hand pump on the plug
- Create excess pressure of 0.2 bar by pumping.



RSV-G and RSV-P

Test pressure 0.2 bar

Tightness is fulfilled if the drop in pressure is ≤ 0.1 bar/min.

*Tightness is **not** fulfilled if the drop in pressure is > 0.1 bar/min.*

If the maximum permissible drop in pressure is not reached, the FEB-O-seals must be replaced and the flanges must be adjusted. ↪ *Chapter 12.3 'Replacing the FEB-O-seals' on page 70*

12. ▶ Move the slide valve into the “active” position

Put the slide valve or ball valve back in the “active” position.

13. ▶ Fit the cover of the gas generator holder back on.

⇒ **The slide valve is ready for operation again.**

13 Commissioning RSV-P



NOTICE!

Please note the chapter [Chapter 13.2 'Commissioning for the inliner version'](#) on page 82 in relation to the inliner version of an RSV.

13.1 Commissioning

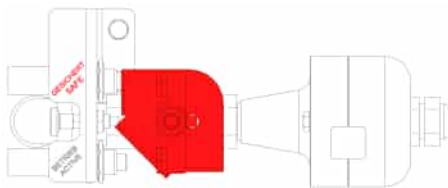

Fig. 94: Gas generator holder in "secured" position

1. ➤ Set the slide valve to the "secured" position if it is not already in this position.
 - Remove the cover of the cladding of the gas generator holder and put it aside with the screws.
 - Tighten the locking bolt, hold it firmly and turn the ball valve simultaneously so that the cam switch sends a signal for the "secured" position via the switch.
- ⇒ The explosion protection slide valve is now secured and work can be carried out on it.



All explosion protection slide valves are delivered in the "secured" position for safety reasons.

2. ➤ Exchange the locking screws for the plug nipple included in the delivery:
 - Remove both locking screws.
 - Screw the locking screws at the place provided for them (on the switch for the "secured" position).
3. ➤ Wire the slide valve via the junction box to the controller according to the electric diagram provided.
4. ➤ Remove the electric bridge according to the electric diagram.
5. ➤ Perform the functionality test according to the "Functionality test" guide.
6. ➤ The slide valve is now ready for use.

13.1.1 Functionality test RSV-G/RSV-P



NOTICE!

With regard to the inliner version of an RSV, it is not possible to carry out a complete functionality test. Please give due consideration to the chapter [Chapter 13.2.1 'Functionality test RSV-G/RSV-P for the inliner version'](#) on page 83 in this regard.

Commissioning RSV-P

Commissioning > Functionality test RSV-G/RSV-P

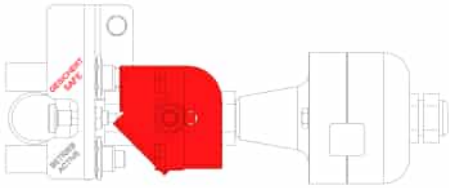

Fig. 95: Gas generator holder in "secured" position

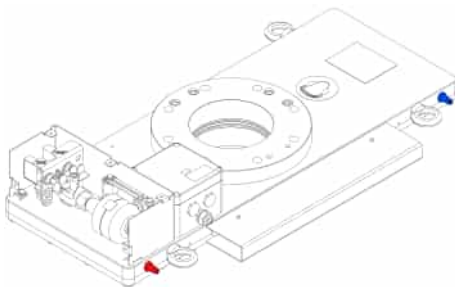

Fig. 96: RSV with plug nipple for OPEN (blue) and CLOSED (red)

1. ➤ Set the slide valve to the "secured" position if it is not already in this position.

- Remove the cover of the cladding of the gas generator holder and put it aside with the screws.
- Tighten the locking bolt, hold it firmly and turn the ball valve simultaneously so that the cam switch sends a signal for the "secured" position via the switch.
If not, check the switches, cables and connections for damage and replace them if need be.

⇒ The explosion protection slide valve is now secured and work can be carried out on it.

2. ➤ Remove the guard plate at the side, which protects the switches from damage, by loosening the two hexagon screws. Put the screws and guard plate aside.

3. ➤ Pneumatically actuate the slide valve.

The following statements describe the pneumatic actuation of a slide valve in its basic design:

- Connect a self-locking coupling to the plug nipple where "ZU/CLOSE" is engraved on the housing. Use a pressure controller here, if available.
- Check whether the slide blade can be moved with 6 bar or if it can be moved to the closed position. If the slide valve cannot be closed with 6 bar, it must be inspected.
- In the closed position, check whether your controller is receiving a signal.
If not, check the switches, cables and connections for damage and replace them if need be.
- Now connect a self-locking coupling to the plug nipple where "AUF/OPEN" is engraved on the housing. Please refer to the information section below for details of the dwell time in the end positions. Then open the slide valve again.
- In the open position, check whether your controller is receiving a signal.
If not, check the switches, cables and connections for damage and replace them if need be.



Activation pressure

The pneumatic pressure for activating the slide valve must be **6 bar**. The pneumatic closing or opening time must be ≤ 6 s and should be measured using the controller.



Dwell time in position "AUF/OPEN"/ "ZU/CLOSE"

In the open and close position, please observe a dwell time of at least **1 minute**.

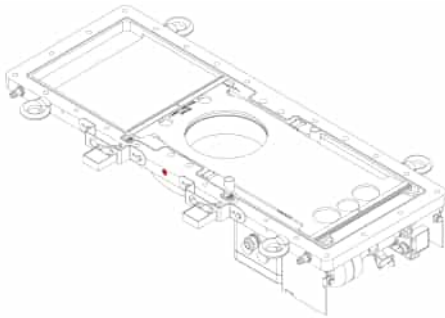

Fig. 97: Non-return valve

4. ➔ Check the non-return valves for a water leak
After pneumatic activation, check if water is leaking at the non-return valves.
If so, the slide valve and compressed air supply must be checked immediately.

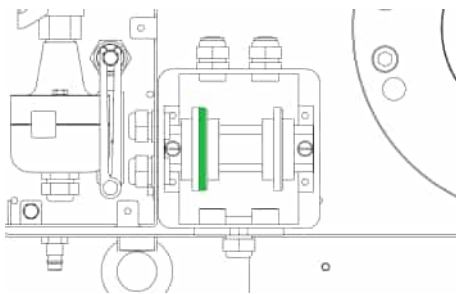

Fig. 98: PE terminal

5. ➔ Checking the earthing
Check if the slide blade is earthed by measuring the resistance from the earthing terminal in the junction box to the slide blade ($\leq 1 \text{ ohm}$).
6. ➔ Check the prescribed screw tightening torques ↪ Chapter 6.4 'Tightening torques' on page 26

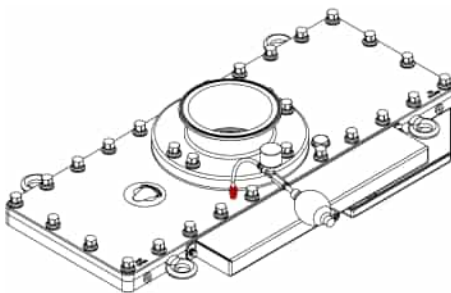

Fig. 99: Gas-tight test of RSV-G and RSV-P

7. ➔ Check the slide valve to see if it is gas-tight using the hand pump included in the delivery.
 - Remove the cap for the threaded nipple and fit the hand pump to it.
 - Create excess pressure of 0.2 bar by pumping.



RSV-G and RSV-P

Test pressure 0.2 bar

Tightness is fulfilled if the drop in pressure is $\leq 0.1 \text{ bar/min}$.

Tightness is **not** fulfilled if the drop in pressure is $> 0.1 \text{ bar/min}$.

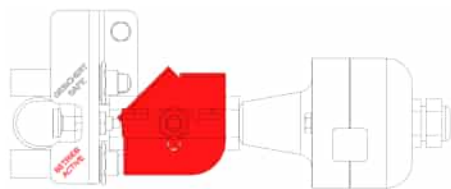

Fig. 100: "Active" position of gas generator holder

8. ➔ Put the slide valve or ball valve in the "active" position and check if the switch is sending a signal for the "active" position.
If not, check the switches, cables and connections for damage and replace them if need be.
9. ➔ Upon completion of the functionality test, the plug nipples need to be removed again and the pneumatic holes need to be sealed by means of locking screws.

Commissioning RSV-P

Commissioning for the inliner version

10. ▶ Assemble all the covers removed earlier using the screws provided for this purpose.

⇒ **If the functionality test is passed successfully, the slide valve can be put into operation.**



Sensors

The use of sensors in an outdoor explosion zone is only permitted during intrinsically safe operation.

13.2 Commissioning for the inliner version

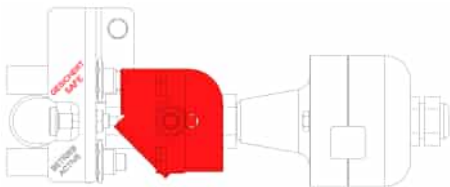

Fig. 101: Gas generator holder in "secured" position

1. ▶ Set the slide valve to the "secured" position if it is not already in this position.

- Remove the cover of the cladding of the gas generator holder and put it aside with the screws.
- Tighten the locking bolt, hold it firmly and turn the ball valve simultaneously so that the cam switch sends a signal for the "secured" position via the switch.

⇒ The explosion protection slide valve is now secured and work can be carried out on it.



All explosion protection slide valves are delivered in the "secured" position for safety reasons.

2. ▶ Wire the slide valve via the junction box to the controller according to the electric diagram provided.

3. ▶ Remove the electric bridge according to the electric diagram.

4. ▶ Perform the functionality test according to the "Functionality test for the inliner version" guide.

5. ▶ The slide valve is now ready for use.

13.2.1 Functionality test RSV-G/RSV-P for the inliner version

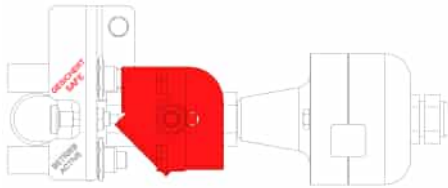

Fig. 102: Gas generator holder in "secured" position

1. ➔ Set the slide valve to the "secured" position if it is not already in this position.

- Remove the cover of the cladding of the gas generator holder and put it aside with the screws.
- Tighten the locking bolt, hold it firmly and turn the ball valve simultaneously so that the cam switch sends a signal for the "secured" position. If not, check the switches, cables and connections for damage and replace them if need be.

⇒ The explosion protection slide valve is now secured and work can be carried out on it.

2. ➔ Remove the guard plate at the side, which protects the switches from damage, by loosening the two hexagon screws. Put the screws and guard plate aside.

3. ➔ Check whether a signal is sent for the "open" position. Conversely, please check that no signal is displayed for the "closed" position.

As the explosion protection slide valve is not to be put in the "closed" position pneumatically in the inliner version, please still proceed as follows to check the switching signal for these switches:

⇒ ■ **Inductive switch:** Check the switching signal using a metal piece such as a screwdriver. See the figure below.

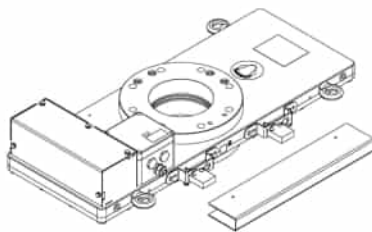

Fig. 103: Disassembly of the guard plate

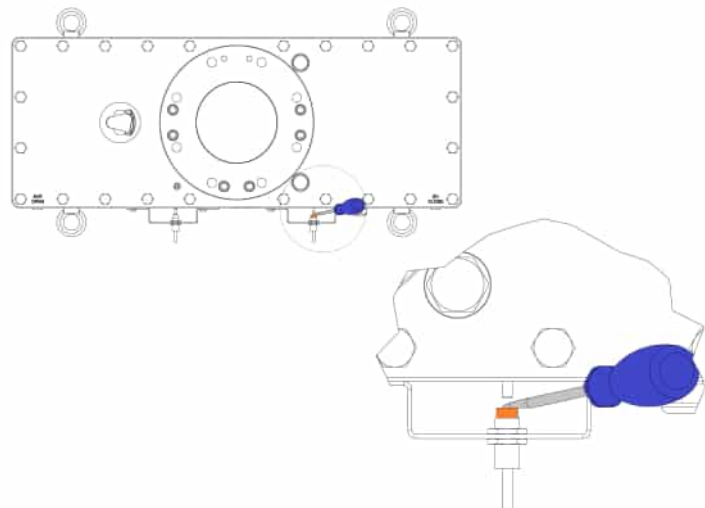

Fig. 104: Checking the switching signal

- **Mechanical switch:** You can actuate the mechanical switch by hand and then check whether a switching signal is displayed.

Commissioning RSV-P

Commissioning for the inliner version > Functionality test RSV-G/RSV-P for the inliner version

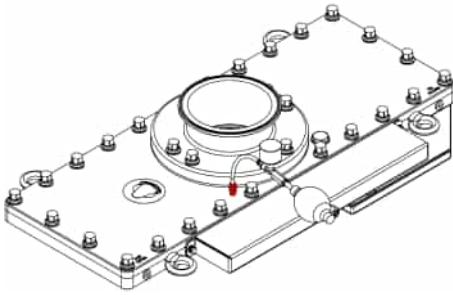

Fig. 105: Gas-tight test of RSV-G and RSV-P

4. ▶ Check the slide valve to see if it is gas-tight using the hand pump included in the delivery.
 - Remove the cap for the threaded nipple and fit the hand pump to it.
 - Create excess pressure of 0.2 bar by pumping.



RSV-G and RSV-P

Test pressure 0.2 bar

Tightness is fulfilled if the drop in pressure is ≤ 0.1 bar/min.

*Tightness is **not** fulfilled if the drop in pressure is > 0.1 bar/min.*

5. ▶ Check the prescribed screw tightening torques. ↪ *Chapter 6.4 'Tightening torques' on page 26*

6. ▶ Put the slide valve or ball valve in the "active" position and check if the switch is sending a signal for the "active" position.

If not, check the switches, cables and connections for damage and replace them if need be.

7. ▶ Assemble all the covers removed earlier using the screws provided for this purpose.

⇒ **If the functionality test is passed successfully, the slide valve can be put into operation.**



Sensors

The use of sensors in an outdoor explosion zone is only permitted during intrinsically safe operation.

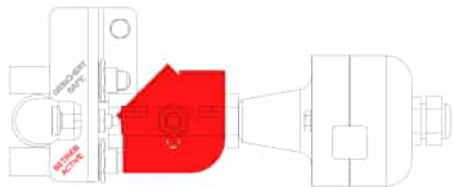

Fig. 106: "Active" position of gas generator holder

14 Maintenance of RSV-P

14.1 Maintenance



The maintenance intervals are dependent on the operating conditions of the slide valve.

*We recommend that you do not actuate the slide valve pneumatically outside the maintenance intervals, in order to prevent the ingress of dust inside the slide valve. However, please ensure that the slide valve **is pneumatically actuated at least once a year.***



WARNING!

Maintenance and inspections in Ex zones

Maintenance and inspections must not be carried out in Ex zones. If this is not possible, appropriate safety measures must be taken and suitable tools must be used.

Maintenance intervals to be observed

Interval	Maintenance work
a) 3 to 5 days after commissioning	Functionality test
b) 3 months	Functionality test, visual and wear monitoring
c) Annually or depending on process	Functionality test, visual and wear monitoring
c) Every 8 years	The gas generator must be replaced no later than after 8 years (see chapter "Gas generator").
d) Every 5 years	All seals must be replaced no later than after 5 years.



Replacing the slide blade

After 10 activations by gas generators, the entire slide blade and the spring-loaded ball bearing must be replaced.



Activation in secured position

In the event of possible activation in the "secured" position, the entire gas generator holder unit must be replaced.

14.1.1 Test process after an explosion/fire

After an explosion or fire, the device must be inspected in accordance with the MB0008 instruction manual and the following points must be checked:

Check of the housing

- Check for deformation of the housing on the outside (across the entire length of the housing)
 - Evenness ≤ 0.5 mm (DN50–DN150)
 - Evenness ≤ 0.8 mm (DN200–DN300)
 - Evenness ≤ 1.0 mm (DN400–DN500)

Check of the flange

- Check for deformation of the flange
 - The axial true running of the flange, from the bearing face to the sealing face, must be ≤ 0.05 mm.

The following parts must be replaced

- – Entire slide blade
- Screw connections
- All seals
- Springs
- Ball bearings
- Non-return valves

Measuring equipment required

- – Measuring table
- Dial gauge, 0.01 mm

Tools required

- – Feeler gauge from 0.1 mm to 1.0 mm
- Hand pump with pressure gauge
- Set of open-ended wrenches from 10 mm to 27 mm
- Set of Allen keys from 4 mm to 17 mm

14.2 Recurring maintenance

14.2.1 Functionality test RSV-G/RSV-P



NOTICE!

With regard to the inliner version of an RSV, it is not possible to carry out a complete functionality test. Please give due consideration to the chapter [Chapter 14.2.2 'Functionality test RSV-G/RSV-P for the inliner version'](#) on page 89 in this regard.

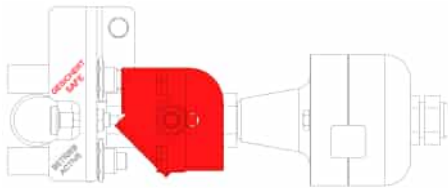

Fig. 107: Gas generator holder in "secured" position

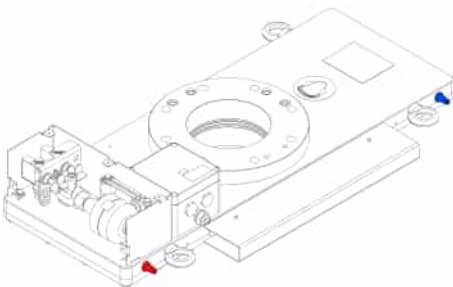

Fig. 108: RSV with plug nipple for OPEN (blue) and CLOSED (red)

1. ➔ Set the slide valve to the "secured" position if it is not already in this position.

- Remove the cover of the cladding of the gas generator holder and put it aside with the screws.
- Tighten the locking bolt, hold it firmly and turn the ball valve simultaneously so that the cam switch sends a signal for the "secured" position via the switch.
If not, check the switches, cables and connections for damage and replace them if need be.

⇒ The explosion protection slide valve is now secured and work can be carried out on it.

2. ➔ Remove the guard plate at the side, which protects the switches from damage, by loosening the two hexagon screws. Put the screws and guard plate aside.

3. ➔ Pneumatically actuate the slide valve.

The following statements describe the pneumatic actuation of a slide valve in its basic design:

- Connect a self-locking coupling to the plug nipple where "ZU/CLOSE" is engraved on the housing. Use a pressure controller here, if available.
- Check whether the slide blade can be moved with 6 bar or if it can be moved to the closed position. If the slide valve cannot be closed with 6 bar, it must be inspected.
- In the closed position, check whether your controller is receiving a signal.
If not, check the switches, cables and connections for damage and replace them if need be.
- Now connect a self-locking coupling to the plug nipple where "AUF/OPEN" is engraved on the housing. Please refer to the information section below for details of the dwell time in the end positions. Then open the slide valve again.
- In the open position, check whether your controller is receiving a signal.
If not, check the switches, cables and connections for damage and replace them if need be.



Activation pressure

The pneumatic pressure for activating the slide valve must be **6 bar**. The pneumatic closing or opening time must be ≤ 6 s and should be measured using the controller.



Dwell time in position "AUF/OPEN"/ "ZU/CLOSE"

In the open and close position, please observe a dwell time of at least **1 minute**.

Maintenance of RSV-P

Recurring maintenance > Functionality test RSV-G/RSV-P

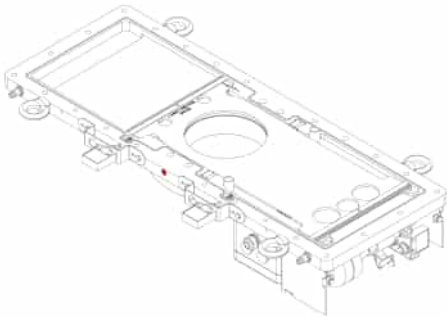

Fig. 109: Non-return valve

4. ▶ Check the non-return valves for a water leak
After pneumatic activation, check if water is leaking at the non-return valves.
If so, the slide valve and compressed air supply must be checked immediately.

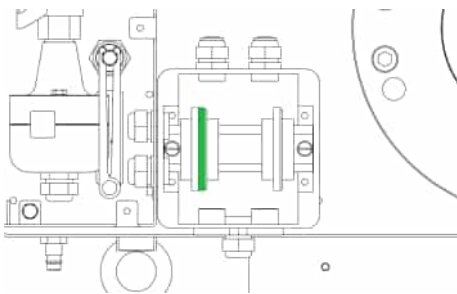

Fig. 110: PE terminal

5. ▶ Checking the earthing
Check if the slide blade is earthed by measuring the resistance from the earthing terminal in the junction box to the slide blade ($\leq 1 \text{ ohm}$).
6. ▶ Check the prescribed screw tightening torques ↪ Chapter 6.4 'Tightening torques' on page 26

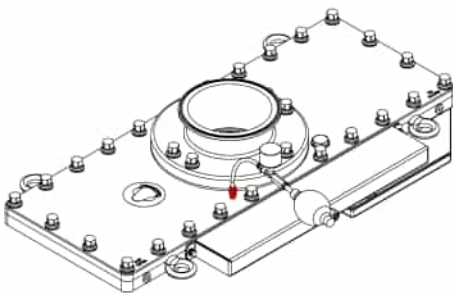

Fig. 111: Gas-tight test of RSV-G and RSV-P

7. ▶ Check the slide valve to see if it is gas-tight using the hand pump included in the delivery.
- Remove the cap for the threaded nipple and fit the hand pump to it.
 - Create excess pressure of 0.2 bar by pumping.



RSV-G and RSV-P

Test pressure 0.2 bar

Tightness is fulfilled if the drop in pressure is $\leq 0.1 \text{ bar/min}$.

Tightness is **not** fulfilled if the drop in pressure is $> 0.1 \text{ bar/min}$.

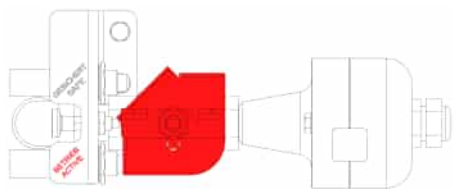

Fig. 112: "Active" position of gas generator holder

8. ▶ Put the slide valve or ball valve in the "active" position and check if the switch is sending a signal for the "active" position.
If not, check the switches, cables and connections for damage and replace them if need be.
9. ▶ Upon completion of the functionality test, the plug nipples need to be removed again and the pneumatic holes need to be sealed by means of locking screws.

10. Assemble all the covers removed earlier using the screws provided for this purpose.

⇒ **If the functionality test is passed successfully, the slide valve can be put into operation.**



Sensors

The use of sensors in an outdoor explosion zone is only permitted during intrinsically safe operation.

14.2.2 Functionality test RSV-G/RSV-P for the inliner version

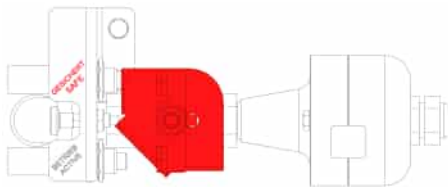

Fig. 113: Gas generator holder in "secured" position

1. Set the slide valve to the "secured" position if it is not already in this position.

- Remove the cover of the cladding of the gas generator holder and put it aside with the screws.
- Tighten the locking bolt, hold it firmly and turn the ball valve simultaneously so that the cam switch sends a signal for the "secured" position via the switch. If not, check the switches, cables and connections for damage and replace them if need be.

⇒ The explosion protection slide valve is now secured and work can be carried out on it.

2. Remove the guard plate at the side, which protects the switches from damage, by loosening the two hexagon screws. Put the screws and guard plate aside.

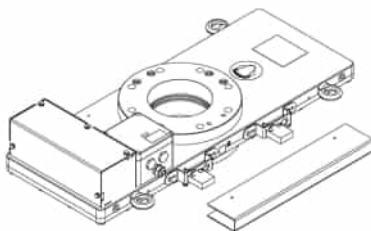

Fig. 114: Disassembly of the guard plate

Maintenance of RSV-P

Recurring maintenance > Functionality test RSV-G/RSV-P for the inliner version

3. Check whether a signal is sent for the "open" position. Conversely, please check that no signal is displayed for the "closed" position.

As the explosion protection slide valve is not to be put in the "closed" position pneumatically in the inliner version, please still proceed as follows to check the switching signal for these switches:

- ⇒ ■ **Inductive switch:** Check the switching signal using a metal piece such as a screwdriver. See the figure below.

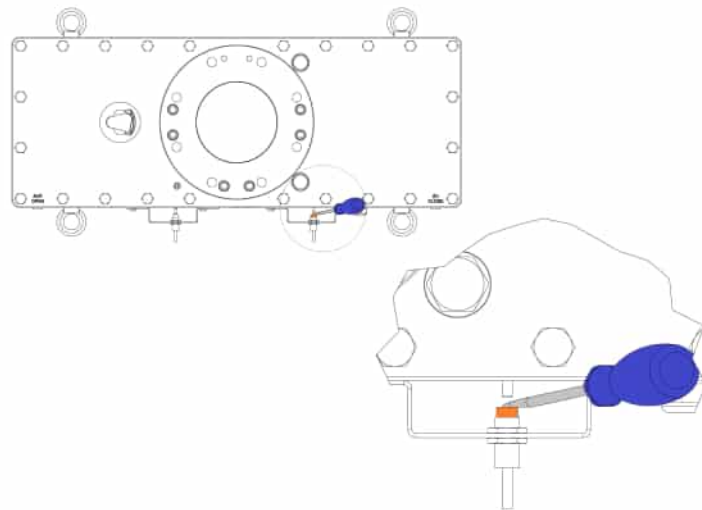

Fig. 115: Checking the switching signal

- **Mechanical switch:** You can actuate the mechanical switch by hand and then check whether a switching signal is displayed.

4. Check the slide valve to see if it is gas-tight using the hand pump included in the delivery.
 - Remove the cap for the threaded nipple and fit the hand pump to it.
 - Create excess pressure of 0.2 bar by pumping.

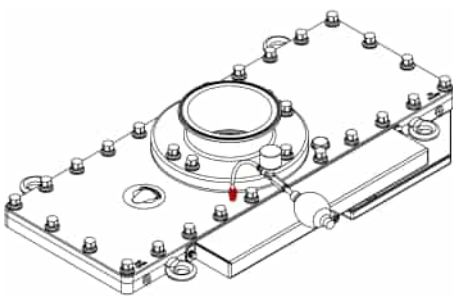

Fig. 116: Gas-tight test of RSV-G and RSV-P



RSV-G and RSV-P

Test pressure 0.2 bar

Tightness is fulfilled if the drop in pressure is ≤ 0.1 bar/min.

Tightness is **not** fulfilled if the drop in pressure is > 0.1 bar/min.

5. Check the prescribed screw tightening torques. ↪ Chapter 6.4 'Tightening torques' on page 26

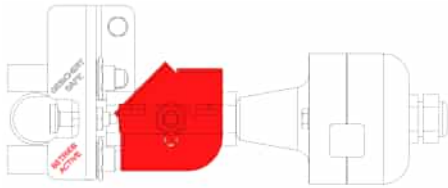

Fig. 117: "Active" position of gas generator holder

6. ➔ Put the slide valve or ball valve in the "active" position and check if the switch is sending a signal for the "active" position.

If not, check the switches, cables and connections for damage and replace them if need be.

7. ➔ Assemble all the covers removed earlier using the screws provided for this purpose.

⇒ **If the functionality test is passed successfully, the slide valve can be put into operation.**



Sensors

The use of sensors in an outdoor explosion zone is only permitted during intrinsically safe operation.

14.2.3 Visual check and wear monitoring



NOTICE!

Please give due consideration to the chapter [Chapter 14.2.4 'Visual check and wear monitoring for the inliner version'](#) on page 92 for the inliner version of an RSV instead of this chapter.

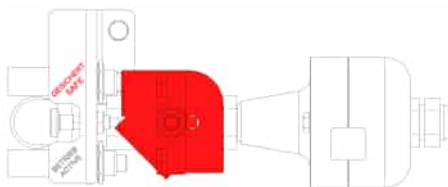

Fig. 118: Gas generator holder in "secured" position

1. ➔ Set the slide valve to the "secured" position if it is not already in this position.

- Remove the cover of the cladding of the gas generator holder and put it aside with the screws.
- Tighten the locking bolt, hold it firmly and turn the ball valve simultaneously so that the cam switch sends a signal for the "secured" position via the switch. If not, check the switches, cables and connections for damage and replace them if need be.

⇒ The explosion protection slide valve is now secured and work can be carried out on it.

2. ➔ Check the housing, passage and junction box for corrosion and mechanical damage.

3. ➔ Check for impurities and deposits

Check whether deposits are present in the area of the lead-through or flanges.

If there are, clean the passage with a cloth moistened with soapy water and then dry it.

Maintenance of RSV-P

Recurring maintenance > Visual check and wear monitoring for the inliner version

4. ▶ Check gas tightness

- Remove the cap for the threaded nipple and fit the hand pump to it.
- Create excess pressure of 0.2 bar by pumping.



RSV-G and RSV-P

Test pressure 0.2 bar

Tightness is fulfilled if the drop in pressure is ≤ 0.1 bar/min.

*Tightness **is not** fulfilled if the drop in pressure is > 0.1 bar/min.*

5. ▶ Flange seal check

Check the flange seals for visible damage.

If they are damaged, they must be replaced.

14.2.4 Visual check and wear monitoring for the inliner version

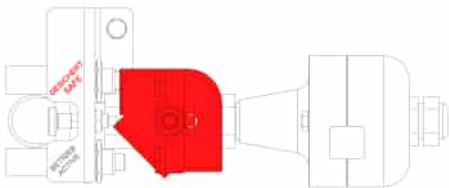

Fig. 119: Gas generator holder in "secured" position

1. ▶ Set the slide valve to the "secured" position if it is not already in this position.

- Remove the cover of the cladding of the gas generator holder and put it aside with the screws.
- Tighten the locking bolt, hold it firmly and turn the ball valve simultaneously so that the cam switch sends a signal for the "secured" position via the switch.
If not, check the switches, cables and connections for damage and replace them if need be.

⇒ The explosion protection slide valve is now secured and work can be carried out on it.

2. ▶ Check the housing and the junction box for corrosion and mechanical damage. Please also check the inliner for abrasion and mechanical damage.

3. ▶ Check for impurities and deposits

Check whether deposits are present in the area of the lead-through or flanges.

If there are, clean the passage with a cloth moistened with soapy water and then dry it.

4. ▶ Check gas tightness

- Remove the cap for the threaded nipple and fit the hand pump to it.
- Create excess pressure of 0.2 bar by pumping.



RSV-G and RSV-P

Test pressure 0.2 bar

Tightness is fulfilled if the drop in pressure is ≤ 0.1 bar/min.

*Tightness is **not** fulfilled if the drop in pressure is > 0.1 bar/min.*

5. ▶ Flange seal check

Check the flange seals for visible damage.

If they are damaged, they must be replaced.

15 Inspection of RSV-P



NOTICE!

Explosive event

The slide valve must be **inspected after every explosion**, when it shows **signs of wear** or **after 5 years**.

Otherwise the function of the slide valve is not ensured.



WARNING!

Maintenance and inspections in Ex zones

Maintenance and inspections must not be carried out in Ex zones. If this is not possible, appropriate safety measures must be taken and suitable tools must be used.

15.1 Gas generator replacement

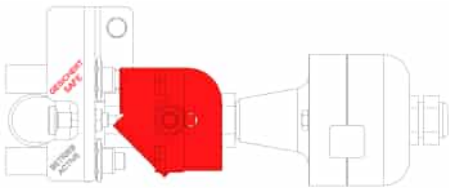

Fig. 120: Gas generator holder in "secured" position

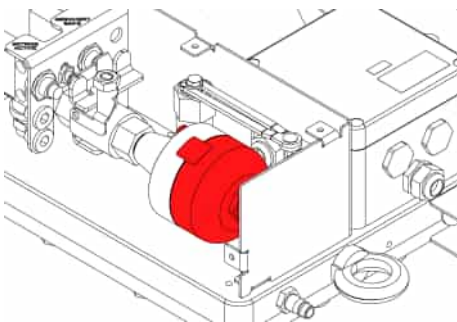
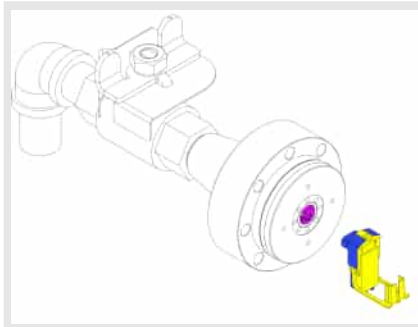

Fig. 121: Cap for gas generator holder

1. ➤ Set the slide valve to the "secured" position if it is not already in this position.
 - Remove the cover of the cladding of the gas generator holder and put it aside with the screws.
 - Tighten the locking bolt, hold it firmly and turn the ball valve simultaneously so that the cam switch sends a signal for the "secured" position via the switch.
2. ➤ Remove the hologram sticker between the cap and gas generator holder.
3. ➤ Remove the hexagon screws holding the cap in place. Remove the cap.

4. ➔ Unplug the ignition cable

Remove the plug-in connector for the gas generator by loosening the fuse and pulling out the plug-in connector.



Plug for RSV DN50–DN150 unplugged

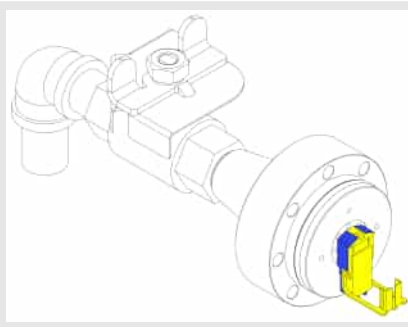

Plug for RSV DN50–DN150 **single-plugged**

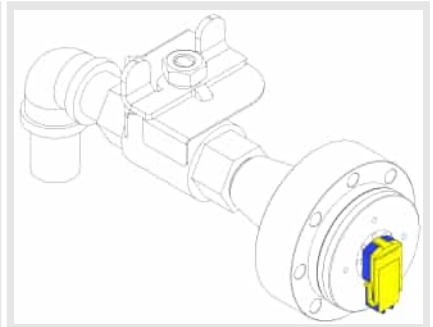

Plug for RSV DN50–DN150 **double-plugged**

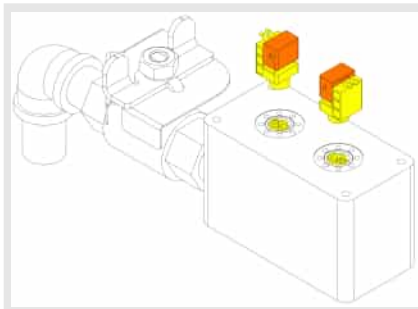

Plug for RSV DN200–DN400 unplugged

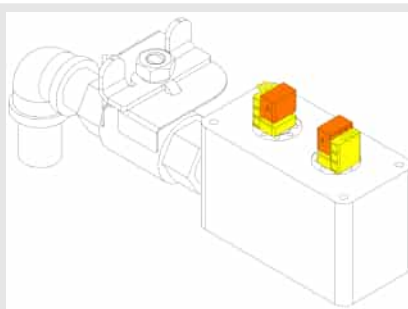

Plug for RSV DN200–DN400 **single-plugged**

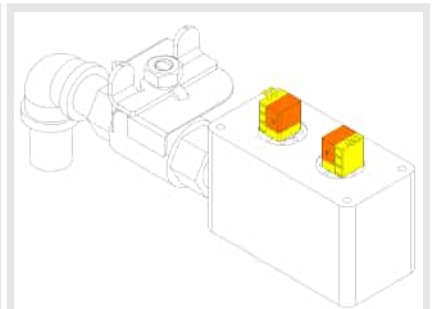

Plug for RSV DN200–DN400 **double-plugged**

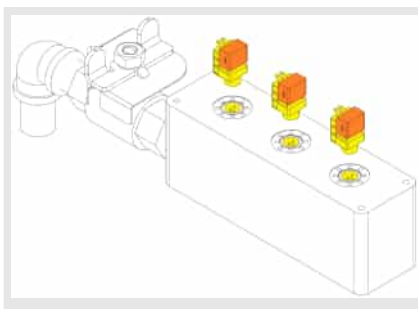

Plug for RSV DN500 unplugged

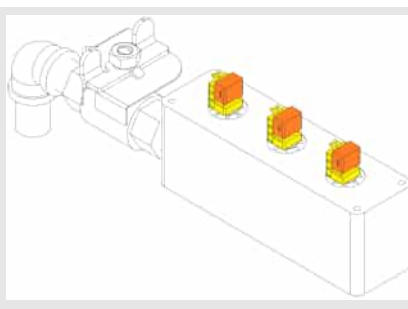

Plug for RSV DN500 **single-plugged**

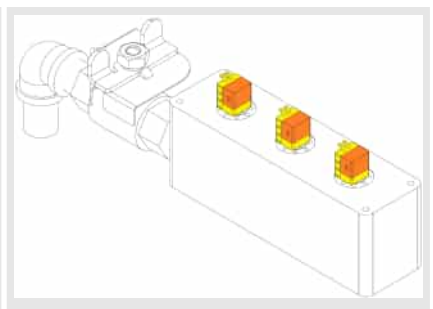

Plug for RSV DN500 **double-plugged**

Inspection of RSV-P

Gas generator replacement

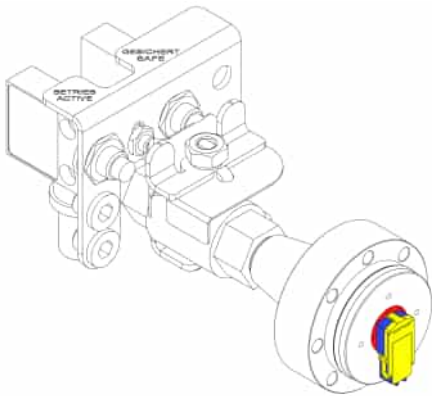

Fig. 122: Spark plug (yellow, blue) and locking screw (red)

5. ▶ Remove the gas generator
 - Take the face spanner included in the delivery out of its holder.
 - Loosen the locking screw from the gas generator holder and remove it.
 - Remove the activated gas generator with pliers and dispose of it. ↪ *Chapter 16 'Disposing of RSV-D / RSV-G and RSV-P' on page 111*
6. ▶ Remove gas generator residue
 - Move the ball valve into the "active" position.
 - Apply 6 bar compressed air to the slide valve in this position via the pneumatic connection "ZU/CLOSE" for 15 seconds.
 - ⇒ Any gas generator residue must now be blown out from the gas generator holder and housing.
7. ▶ Before continuing with the work, move the ball valve or slide valve back into the "secured" position.

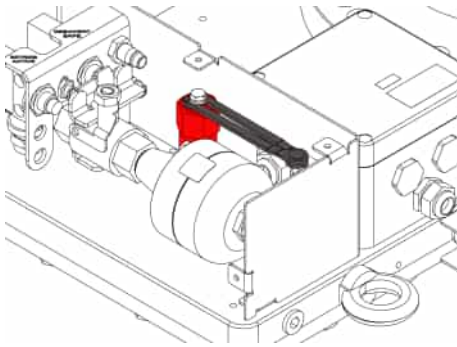
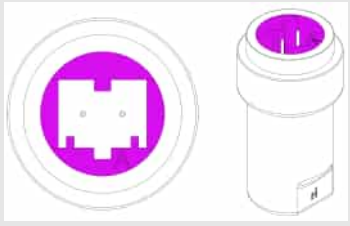
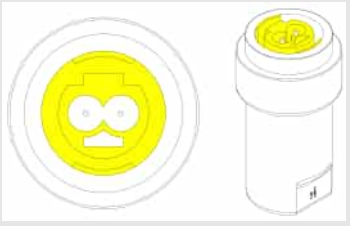

Fig. 123: Spare gas generator holder (red) and face pin wrench

8. Insert the gas generator

- Remove the new gas generator(s) (depending on their nominal width) from the spare gas generator holder by unscrewing it/them.
- Remove the new gas generators, buffers and hologram stickers.
- Apply a little high-temperature grease (e.g. Klüber Wolf-racoat C) to the gas generator.
Insert the new gas generator(s) (depending on their nominal width) and re-tighten with the locking screw.
- Plug the ignition cable(s) back in so that it locks in place twice.
- **Place the cap of the generator on it and fix it again with its hexagon screws.**
- Stick one of the new hologram labels on the cap and gas generator holder.
- Screw back the empty spare gas generator holder and face spanner into the positions provided for this.

	
Gas generator charge 0.8 g DN50–DN150 Article no. 010138	Gas generator charge 1.3 g DN200–DN500 Article no. 126323



Reactivation kit

Order new gas generators, buffers and hologram stickers immediately. For this, use the MF0006DE form, which can be downloaded at www.service.rico.ch or <http://www.rico.ch/de/download>.

Ensure that the new gas generators and buffers reach the spare gas generator holders provided for this right away and are thus always available.



CAUTION!

Do not move the ball valve or slide valve into the “active” position yet.

Inspection of RSV-P

Replacing the gas generator holder

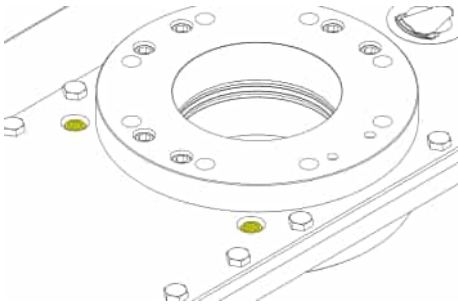

Fig. 124: Buffer without locking keys

9. ▶ Replace the buffers

- Remove the locking screw on the upper housing and put it aside.
- Move the slide valve or slide blade to the “open” position according to the functional test. ↪ *Chapter 8.2.1 ‘Functionality test’ on page 33*
If this is not successful, extend the buffers using a large screwdriver, so that the slide valve can be actuated or opened pneumatically.
- Remove the destroyed buffers using pliers and/or a screwdriver.
- Insert the new buffers included in the delivery.
- Re-tighten the locking screws firmly.

10. ▶ Change hologram stickers on the housing

- Remove the lateral guard plate.
- Remove the existing hologram sticker and replace it with the new one so that it has the same number as the sticker on the gas generator holder.
- Fit the lateral guard plate back.

11. ▶ Move the slide valve into the “active” position

Move the slide valve or ball valve back into the “active” position.

12. ▶ Fit the cover of the gas generator holder.

⇒ **The slide valve is ready for operation again.**

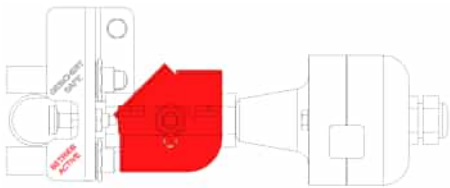

Fig. 125: “Active” position of gas generator holder

15.2 Replacing the gas generator holder

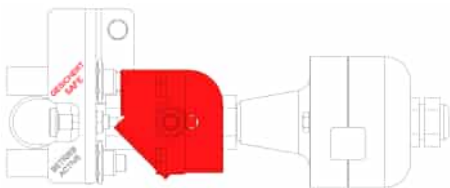

Fig. 126: Gas generator holder in “secured” position

1. ▶ Set the slide valve to the “secured” position if it is not already in this position.

- Remove the cover of the cladding of the gas generator holder and put it aside with the screws.
- Tighten the locking bolt, hold it firmly and turn the ball valve simultaneously so that the cam switch sends a signal for the “secured” position via the switch.

2. ▶ Remove the hologram sticker between the cap and gas generator holder.

3. ▶ Remove the hexagon screws holding the cap in place. Remove the cap.

4. ▶ Unplug the ignition cable

Remove the plug-in connector for the gas generator by loosening the safeguard and pulling out the plug-in connector.

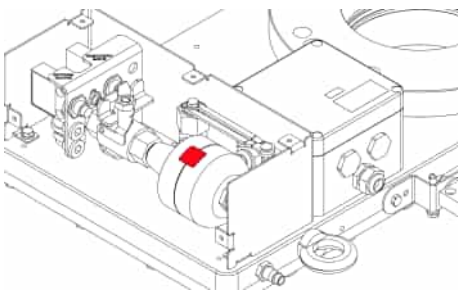

Fig. 127: Hologram stickers

- 5.** ➤ Remove the gas generator
- Take the face spanner included in the delivery out of its holder.
 - Loosen the locking screw from the gas generator holder and remove it.
 - Remove the activated gas generator with pliers and dispose of it. ⚠ *'Ignited gas generators' on page 111*

- 6.** ➤ Remove the junction box
- Open the junction box by loosening the four screws.
 - Remove the junction box by loosening the four cylinder head screws inside the junction box.



There is no need to interfere with the cables.

- Remove the entire cladding of the gas generator holder.
- Remove the spare gas generator holder.
- Remove the holder of both switches for the position "active" and "secured", and the earthing cable.

⇒ The gas generator holder is now free.

- 7.** ➤ Remove the gas generator holder
- Heat the fitting with a hot air dryer so that it can be "unlocked" and loosened.
 - Turn the gas generator holder including the threaded fitting until it can be removed, and dispose of the gas generator holder.
- 8.** ➤ Via the pneumatic connection "ZU/CLOSE", apply 6 bar compressed air to the slide valve for 15 seconds in this position. This will blow out any residue from the gas generator.
- 9.** ➤ Coat the thread fitting with Loctite 577 thread sealant.
- 10.** ➤ Now, screw on the new gas generator holder so that the axis of the ball valve is parallel to the housing.

Inspection of RSV-P

Replacing the FEP-O-seals

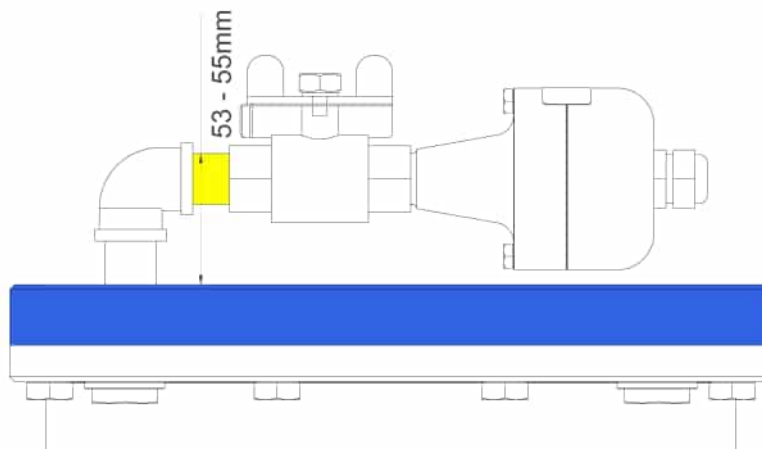

Fig. 128: Installation height, RSV gas generator holder

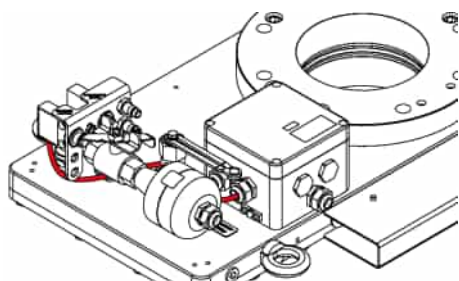

Fig. 129: Route of switch cable

11. ▶ Install the universal holder, cladding, junction box and spare gas generator holder.
Install the switch holder with the earthing. Ensure that the cable between the junction box and switch goes under the gas generator holder and switch holder.
12. ▶ Now, move the ball valve or **slide valve back into the “secured” position.**
13. ▶ Assemble or fix the cladding of the gas generator holder again.
14. ▶ Fit and connect the junction box back correctly.
15. ▶ Continue according to [Chapter 15.1 ‘Gas generator replacement’ on page 94](#), point 8 “Inserting the gas generator”.

15.3 Replacing the FEP-O-seals

1. ▶ Set the slide valve to the “secured” position if it is not already in this position.
 - Remove the cover of the cladding of the gas generator holder and put it aside with the screws.
 - Tighten the locking bolt, hold it firmly and turn the ball valve simultaneously so that the cam switch sends a signal for the “secured” position via the switch.

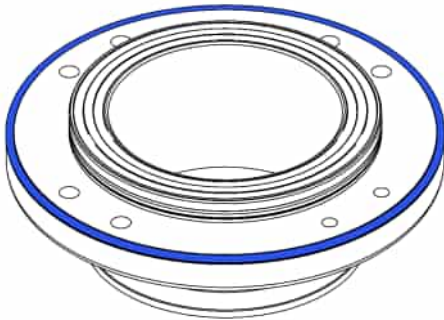

Fig. 130: RSV-P outer flange seal, for pharmaceutical applications

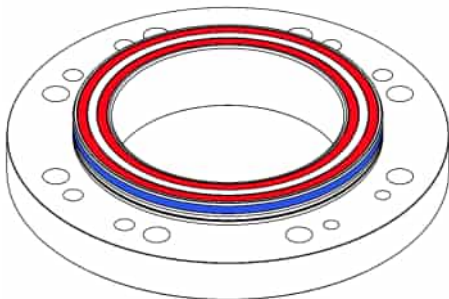

Fig. 131: FEP-O-seal (red) and outer flange seal (blue) of RSV-G

2. ➤ Removing the flange connection

First remove a flange, change the FEP-O-seals and repeat the following steps for the other side. For the RSV-P design, the outer flange seal for pharmaceutical applications must be replaced.

- Loosen and remove all screws on the respective flange.
- On the other side, loosen and remove only those screws that have through-holes.



If there were shim rings on the side on which you just removed the flange, re-insert them in the same position when assembling the flange.

3. ➤ On the flange that has been removed, remove the FEB-O-seal and the outer flange seal or, in the case of RSV-P, even the flange seal for pharmaceutical applications.

4. ➤ Clean the flange using a cloth moistened with soapy water.

5. ➤ Fit the new seals in reverse order.

6. ➤ Fit the flange back into its original position. Note the permitted tightening torques of the screws. ↪ Chapter 6.4 'Tightening torques' on page 26

7. ➤ Repeat steps 2 to 6 for the second flange connection.

8. ➤ Perform a functionality test.

15.3.1 Replacing the inliner seal

1. ➤ Set the slide valve to the "secured" position if it is not already in this position.

- Remove the cover of the cladding of the gas generator holder and put it aside with the screws.
- Tighten the locking bolt, hold it firmly and turn the ball valve simultaneously so that the cam switch sends a signal for the "secured" position via the switch.

2. ➤ Remove the flange connection

First remove one flange.

- Loosen and remove all screws on the respective flange.
- On the other side, loosen and remove only those screws that have through-holes.



If there were shim rings on the side on which you just removed the flange, re-insert them in the same position when assembling the flange.

3. ➤ Clean the flange using a cloth moistened with soapy water.

Inspection of RSV-P

Replacing the FEP-O-seals > Replacing the inliner seal

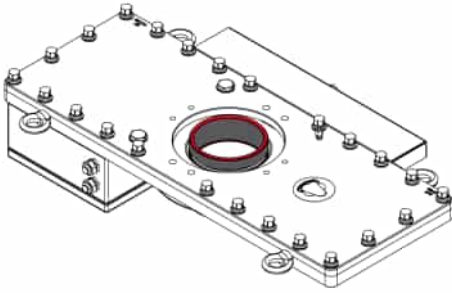

Fig. 132: PTFE inliner with O-ring

4. ➤ Remove the PTFE inliner by manually pulling it out of the bore carefully.
5. ➤ Remove the inliner seals and place the new seals properly in the correct positions.
6. ➤ Fit the flange back into its original position. Note the permitted tightening torques of the screws. ↪ Chapter 6.4 'Tightening torques' on page 26
7. ➤ Check gas tightness
 - Remove the threaded nipple and fit the hand pump on the plug
 - Create excess pressure of 0.2 bar by pumping



RSV-G and RSV-P

Test pressure 0.2 bar

Tightness is fulfilled if the drop in pressure is ≤ 0.1 bar/min.

Tightness **is not** fulfilled if the drop in pressure is > 0.1 bar/min.

If the maximum permissible drop in pressure is not reached, the FEB-O-seals must be replaced and the flanges must be adjusted. ↪ Chapter 15.3 'Replacing the FEP-O-seals' on page 100

8. ➤



NOTICE!

Do not perform a functionality test yet under any circumstances.



Commissioning

- Move the pneumatic function control to "AUF/OPEN" and "ZU/CLOSE". It is not possible to test the inliner version when it is installed.
- The inliner version may only be connected when the pneumatic connection is set to "AUF/OPEN" and actuated for the functionality test.

9. ➤ Move the slide valve into the "active" position
Put the slide valve or ball valve back in the "active" position.
10. ➤ Fit the cover of the gas generator holder back on.
⇒ **The slide valve is ready for operation again.**

Replacing the PTFE inliner after a release

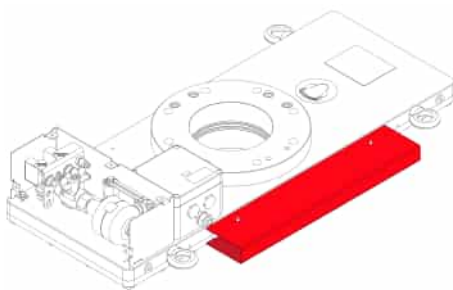

Fig. 133: Side cladding of RSV-D and -G

1. ➤ Set the slide valve to the “secured” position if it is not already in this position.
 - Remove the cover of the cladding of the gas generator holder and put it aside with the screws.
 - Tighten the locking bolt, hold it firmly and turn the ball valve simultaneously so that the cam switch sends a signal for the “secured” position via the switch.
2. ➤ Remove the side cladding. In the case of RSV-P, also remove the deaerator.
3. ➤ Remove the flange
 - Loosen and remove all screws on the respective flange.
 - On the other side, loosen and remove only those screws that have through-holes.



If there were shim rings on the side on which you just removed the through bolts, re-insert them in the same position when assembling the flange.

4. ➤ Remove the housing
 - Loosen all screws on the upper housing.
 - Remove the upper half of the housing using the lifting eye bolts provided by screwing them onto the flange, and put it aside.
5. ➤ Remove and dispose of the PTFE inliner and its residues.
6. ➤ Remove the buffer.
7. ➤ Remove the slide blade



Remove the entire slide blade and put it aside on a clean, scratch-free surface.

8. ➤ Clean both halves of the housing with a cloth moistened with soapy water and then dry them.

Inspection of RSV-P

Replacing the FEP-O-seals > Replacing the inliner seal

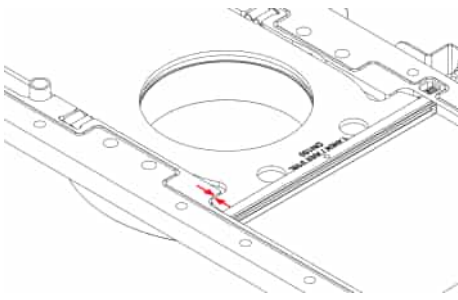

Fig. 134: Correctly inserted slide blade

- 9.** ▶
- Reinsert the slide blade correctly (the two engraved arrow heads must point at each other).
 - Check whether the slide blade is inserted correctly and can be moved by hand past the ball bearings to the positions “open” and “close”.

- 10.** ▶ Insert the PTFE inliner
- Remove the inliner seals and place the new seals in the correct positions in the flange groove.
 - Place the new PTFE inliner in the place provided for it and ensure that the seal sits properly on the PTFE inliner.

- 11.** ▶ Assemble the halves of the housing
- In order to assemble the halves of the housing, repeat steps 2 to 5 in reverse order.

- 12.** ▶ Check gas tightness
- Remove the threaded nipple and fit the hand pump on the plug
 - Create excess pressure of 0.2 bar by pumping



RSV-G and RSV-P

Test pressure 0.2 bar

Tightness is fulfilled if the drop in pressure is ≤ 0.1 bar/min.

*Tightness **is not** fulfilled if the drop in pressure is > 0.1 bar/min.*

If the maximum permissible drop in pressure is not reached, the FEB-O-seals must be replaced and the flanges must be adjusted. ↪ *Chapter 15.3 ‘Replacing the FEP-O-seals’ on page 100*

- 13.** ▶
- NOTICE!**
Do not perform a functionality test yet under any circumstances.

- 14.** ▶ Gas generator replacement
- Follow the instructions in Chapter “Replacing the gas generator”. ↪ *Chapter 15.1 ‘Gas generator replacement’ on page 94*

- 15.** ▶ Move the slide valve into the “active” position
- Put the slide valve or ball valve back in the “active” position.

- 16.** ▶ Fit the cover of the gas generator holder back on.
- ⇒ **The slide valve is ready for operation again.**

15.4 Replacing the seals on the housing and gas generator holder

1. ➤ Set the slide valve to the “secured” position if it is not already in this position.
 - Remove the cover of the cladding of the gas generator holder and put it aside with the screws.
 - Tighten the locking bolt, hold it firmly and turn the ball valve simultaneously so that the cam switch sends a signal for the “secured” position via the switch.

2. ➤ Remove the side cladding.

3. ➤ Remove only the through bolts of the flange.



If there were shim rings on the side on which you just removed the through bolts, re-insert them in the same position when assembling the flange.

4. ➤ Remove the housing

- Loosen all screws on the upper housing.
- Remove the upper housing using the lifting eye bolts provided by screwing them onto the flange, and put it aside.

5. ➤ Remove the buffer and put it aside

6. ➤ Remove the slide blade



Remove the entire slide blade and put it aside on a clean, scratch-free surface.

7. ➤ Replace the seal on non-return valves

Repeat the following steps for all three non-return valves on the slide valve.

- Remove the face spanner under the cladding of the gas generator holder.
- Unscrew the non-return valve from the relevant side using the face spanner.
- Replace the seal or O-ring with a new one.
- Screw back the non-return valve in a flush-mounted manner so that the seal is compressed.
If the non-return valve can be screwed into the hole, counter this from outside with the throttle insert by removing the pneumatic fittings and then refitting them.
- Repeat the steps above for all three non-return valves at the slide valve.

Inspection of RSV-P

Replacing the seals on the housing and gas generator holder

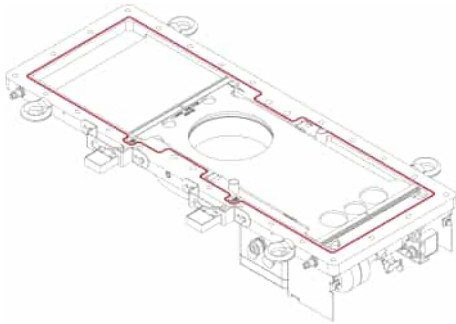

Fig. 135: Housing seal

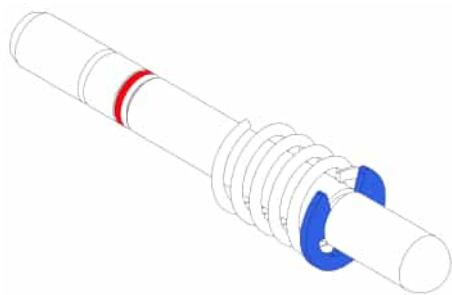

Fig. 136: Switch rod with O-ring (red) and locking ring (blue)

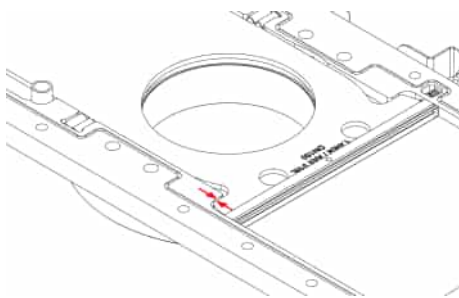

Fig. 137: Correctly inserted slide blade

8. ▶ Remove and dispose of the housing seal.

9. ▶ Replace the seal of the switch rod

Repeat the steps below for both switch rods.

- Remove the universal holder on which the switches for signalling the slide blade's position are fixed.
- Remove the circlip of the switch rod using a small screwdriver.
- Pull the switch rod carefully out of the housing.
- Replace the O-ring on the switch rod.
- Carry out the steps above again in reverse order and re-assemble the switch rod correctly.
- Repeat the steps above for the second switch rod.

10. ▶ Clean both halves of the housing with a cloth moistened with soapy water and then dry them.

11. ▶ Insert the new, clean housing seal.

12. ▶ Reinsert the slide blade correctly (the two engraved arrow heads must point at each other).

13. ▶ Re-assemble the housing and screw it together properly.
↪ *Chapter 6.4 'Tightening torques' on page 26*

14. ▶ Insert the buffers properly from outside. See also ↪ *Chapter 15.1 'Gas generator replacement' on page 94.*

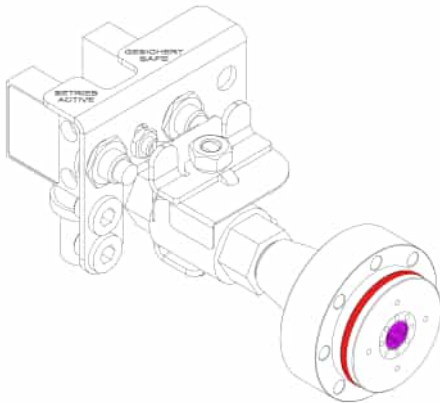

Fig. 138: Seal for the gas generator holder

15. Replace the seal for the gas generator holder

Follow points 1 to 4 to replace the seal of the gas generator holder. Replace the gas generator. ↪ *Chapter 15.1 'Gas generator replacement' on page 94*

16. Replace the seal. Plug the ignition cable(s) back in so that it locks in place twice. Then fit the cap of the gas generator holder and fix it again with its hexagon screws. After assembly, attach the new hologram sticker in the original place. Follow points 10 to 12. Replace the gas generator holder. ↪ *Chapter 15.1 'Gas generator replacement' on page 94*

15.5 Replacing the seal for RSV-P

1. Set the slide valve to the "secured" position if it is not already in this position.

- Remove the cover of the cladding of the gas generator holder and put it aside with the screws.
- Tighten the locking bolt, hold it firmly and turn the ball valve simultaneously so that the cam switch sends a signal for the "secured" position via the switch.

2. Remove the side cladding and deaerator.

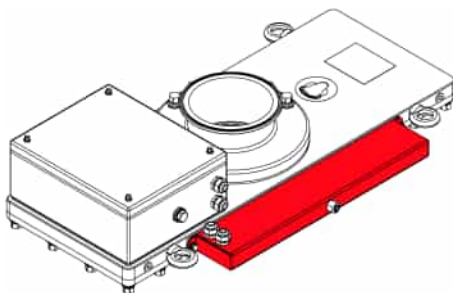

Fig. 139: Side cladding of RSV-P

3. Replace the seal and reassemble the side cladding including the deaerator into the position provided for them.

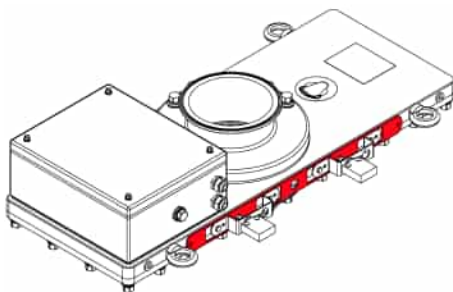

Fig. 140: Seal of side cladding of RSV-P

Inspection of RSV-P

Replacing the slide blade

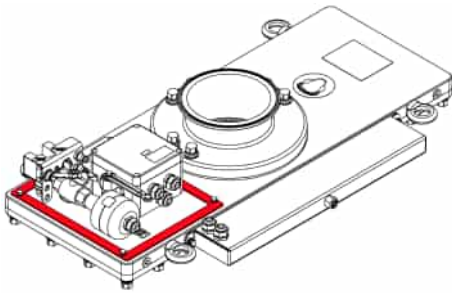

Fig. 141: Seal for cladding for pharmaceutical applications

4. ▶ Replacing the seal for cladding for pharmaceutical applications
 - Loosen the screws of the cladding for pharmaceutical applications inside in order to remove the housing.
 - Replace the cover seal and housing seal.
 - Screw the cladding for pharmaceutical applications back on to the housing.
5. ▶ Move the slide valve into the “active” position
Move the slide valve or ball valve back into the “active” position.
6. ▶ Fit the cover of the gas generator holder back on.
⇒ **The slide valve is ready for operation again.**

15.6 Replacing the locking screw seal

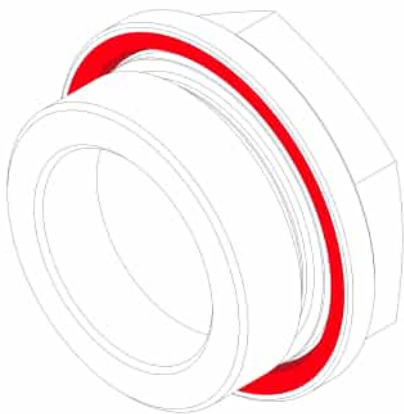

Fig. 142: Seal for buffer locking screw

1. ▶ Set the slide valve to the “secured” position if it is not already in this position.
 - Remove the cover of the cladding of the gas generator holder and put it aside with the screws.
 - Tighten the locking bolt, hold it firmly and turn the ball valve simultaneously so that the cam switch sends a signal for the “secured” position via the switch.
2. ▶ Remove the locking screws
 - Remove both the locking screws on the upper housing and remove the O-rings.
 - Fit new O-rings in the places provided for them.
 - Re-tighten the locking screws on the upper housing firmly.
3. ▶ Move the slide valve into the “active” position
Put the slide valve or ball valve back in the “active” position.
4. ▶ Fit the cover of the gas generator holder back on.
⇒ **The slide valve is ready for operation again.**

15.7 Replacing the slide blade

1. ▶ Set the slide valve to the “secured” position if it is not already in this position.
 - Remove the cover of the cladding of the gas generator holder and put it aside with the screws.
 - Tighten the locking bolt, hold it firmly and turn the ball valve simultaneously so that the cam switch sends a signal for the “secured” position via the switch.

2. ➤ Remove the side cladding.
3. ➤ Remove only the through bolts of the flange.



If there were shim rings on the side on which you just removed the through bolts, re-insert them in the same position when assembling the flange.

4. ➤ Remove the housing
 - Loosen all screws on the upper housing.
 - Remove the upper half of the housing using the lifting eye bolts provided by screwing them onto the flange, and put it aside.

5. ➤ Remove the buffer and put it to one side.

6. ➤ Remove the slide blade

Remove the entire slide blade and the ball bearings. Dispose of them.

7. ➤ Clean both halves of the housing with a cloth moistened with soapy water and then dry them.

8. ➤ Replacing the slide blade

- Now place the new slide blade completely into one half of the housing.
- Check whether the slide blade is inserted correctly and can be moved by hand past the newly inserted ball bearings to the positions “open” and “closed”.



The slide blade is inserted correctly if the arrow heads are aligned against each other (arrow pointing at arrow).

(Slide blade of RSV-G/RSV-P nominal width = faceted, RSV-D nominal width not faceted)

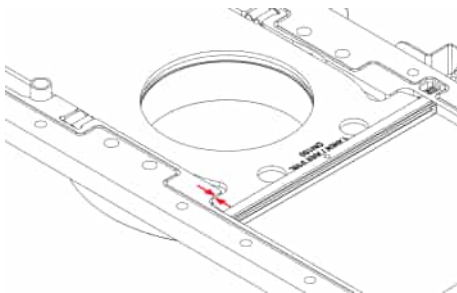

Fig. 143: Correctly inserted slide blade

10. ➤ Assemble the halves of the housing

In order to assemble the halves of the housing, repeat steps 2 to 5 in reverse order.

Inspection of RSV-P

Replacing the slide blade

11. ▶ Check gas tightness

- Remove the threaded nipple and fit the hand pump on the plug
- Create excess pressure of 0.2 bar by pumping.



RSV-G and RSV-P

Test pressure 0.2 bar

Tightness is fulfilled if the drop in pressure is ≤ 0.1 bar/min.

*Tightness is **not** fulfilled if the drop in pressure is > 0.1 bar/min.*

If the maximum permissible drop in pressure is not reached, the FEB-O-seals must be replaced and the flanges must be adjusted. ↪ *Chapter 15.3 'Replacing the FEB-O-seals' on page 100*

12. ▶ Move the slide valve into the “active” position

Put the slide valve or ball valve back in the “active” position.

13. ▶ Fit the cover of the gas generator holder back on.

⇒ **The slide valve is ready for operation again.**

16 Disposing of RSV-D / RSV-G and RSV-P

16.1 Disposal

The product must be handed over to a specialised disposal company which is able to recycle the separated materials, in accordance with the locally applicable disposal regulations. A copy of the operating instructions must be given to the disposal company. The manufacturer bears no liability for damages to people, material or the environment which result from improper disposal of the product.

16.2 Gas generator



DANGER!

Non-ignited gas generators

Gas generators which have not been ignited must be disposed of by an **authorised company**. If you have any questions, please contact us at info@rico.ch.



Ignited gas generators

Gas generators which have been ignited can be sent to a normal metal processing plant.

17 Maintenance book

Maintenance book

Customer / Kunde / Client:	
Type / Typ / Modèle: Fabrication no. / Fabrikations-Nr. / No. de fabrication:	
Installed at / Installiert in Anlage / Installée chez:	
Date of delivery / Lieferdatum / Date de livraison: Date valve was put into service / Inbetriebnahme / Date de mise en service:	

Date / Datum	Visit / Besuch / Visite		Time / Zeit / Heure	Objection / Beanstandung / Constatation
	Service/Wartung			
	Repair / Reperatur / Réparation	Solved / erledigt / exécution		
	Fault / Störung / Défault			
	Service/Wartung			
	Repair / Reperatur / Réparation	Solved / erledigt / exécution		
	Fault / Störung / Défault			
	Service/Wartung			
	Repair / Reperatur / Réparation	Solved / erledigt / exécution		
	Fault / Störung / Défault			
	Service/Wartung			
	Repair / Reperatur / Réparation	Solved / erledigt / exécution		
	Fault / Störung / Défault			
	Service/Wartung			
	Repair / Reperatur / Réparation	Solved / erledigt / exécution		
	Fault / Störung / Défault			
	Service/Wartung			
	Repair / Reperatur / Réparation	Solved / erledigt / exécution		
	Fault / Störung / Défault			
	Service/Wartung			
	Repair / Reperatur / Réparation	Solved / erledigt / exécution		
	Fault / Störung / Défault			

Reason / Ursache / Cause	Repair / Behebung / Réparation	Spare Parts / Ersatzteile / Pièce de rechange	Engineer. / Techn. / Ing.

Date / Datum	Visit / Besuch / Visite		Time / Zeit / Heure	Objection / Beanstandung / Constatation
	Service/Wartung			
	Repair / Reperatur / Réparation	Solved / erledigt / exécution		
	Fault / Störung / Défault			
	Service/Wartung			
	Repair / Reperatur / Réparation	Solved / erledigt / exécution		
	Fault / Störung / Défault			
	Service/Wartung			
	Repair / Reperatur / Réparation	Solved / erledigt / exécution		
	Fault / Störung / Défault			
	Service/Wartung			
	Repair / Reperatur / Réparation	Solved / erledigt / exécution		
	Fault / Störung / Défault			
	Service/Wartung			
	Repair / Reperatur / Réparation	Solved / erledigt / exécution		
	Fault / Störung / Défault			
	Service/Wartung			
	Repair / Reperatur / Réparation	Solved / erledigt / exécution		
	Fault / Störung / Défault			
	Service/Wartung			
	Repair / Reperatur / Réparation	Solved / erledigt / exécution		
	Fault / Störung / Défault			

Reason / Ursache / Cause	Repair / Behebung / Réparation	Spare Parts / Ersatzteile / Pièce de rechange	Engineer. / Techn. / Ing.

Date / Datum	Visit / Besuch / Visite		Time / Zeit / Heure	Objection / Beanstandung / Constatation
	Service/Wartung			
	Repair / Reperatur / Réparation	Solved / erledigt / exécution		
	Fault / Störung / Défault			
	Service/Wartung			
	Repair / Reperatur / Réparation	Solved / erledigt / exécution		
	Fault / Störung / Défault			
	Service/Wartung			
	Repair / Reperatur / Réparation	Solved / erledigt / exécution		
	Fault / Störung / Défault			
	Service/Wartung			
	Repair / Reperatur / Réparation	Solved / erledigt / exécution		
	Fault / Störung / Défault			
	Service/Wartung			
	Repair / Reperatur / Réparation	Solved / erledigt / exécution		
	Fault / Störung / Défault			
	Service/Wartung			
	Repair / Reperatur / Réparation	Solved / erledigt / exécution		
	Fault / Störung / Défault			
	Service/Wartung			
	Repair / Reperatur / Réparation	Solved / erledigt / exécution		
	Fault / Störung / Défault			

Reason / Ursache / Cause	Repair / Behebung / Réparation	Spare Parts / Ersatzteile / Pièce de rechange	Engineer. / Techn. / Ing.

18 Index

- A**
- Activation in secured position 31, 55, 85
 - Aids required 26
 - Assembly 25
 - Assembly diagram 18, 21, 24
 - ATEX zones 17, 20, 23
- C**
- Cleaning
 - 36, 43, 44, 47, 61, 62, 70, 74, 77, 91, 92, 100, 105, 108
 - Combination with other products 15
 - Commissioning RSV-D 28
 - Commissioning RSV-G 49
 - Commissioning RSV-P 79
 - Conditioned compressed air 27
- D**
- Decontamination declaration 14
 - Direction of explosion 25
 - Disposal 111
- E**
- Earthing 27
 - EC safety data sheet 18, 21, 24
 - Electric diagram 27
 - Equipment category 17, 20, 23
 - Equipment group 17, 20, 23
 - Explosion pressure 17, 20, 23
 - Explosive event 37, 64, 94
- F**
- Functional principle 16, 19, 22
 - Functionality test
 - 28, 33, 50, 53, 57, 59, 80, 83, 87, 89
- G**
- Gap dimensions 36, 61, 62, 91, 92
 - Gas generator 18, 21, 24
 - Gas generator replacement 37, 64, 94
 - Gas generator secured in position 14
- I**
- Ignited gas generators 111
 - Ignition current 15
 - Incomplete machine 16, 19, 22
 - Inspection 37, 64, 94
 - Installation guideline 17, 20, 23
 - Installation position 26
 - Insulation 25
 - Intended use 11
- J**
- Junction box 27
- M**
- Machinery Directive 2006/42/EC 16, 19, 22
 - Maintenance 31, 55, 85
 - Maintenance intervals to be observed . . 31, 55, 85
 - Manufacturer 7
 - Media 17, 20, 23
- N**
- Name plate 18, 21, 24
 - Non-ignited gas generators 111
- P**
- Parts list 18, 21, 24
 - Plug-in connector
 - 28, 33, 50, 53, 57, 59, 80, 83, 87, 89
 - Pneumatics 27
 - Pressure shock-resistant design 16, 19, 22
 - Process temperature 17, 20, 23
 - Protection system 16, 17, 19, 20, 22, 23
- R**
- Recurring maintenance 33, 56, 86
 - Replacing the active seals 43
 - Replacing the FEP-O-seal 70, 100
 - Replacing the gas generator holder 41, 68, 98
 - Replacing the housing seal 44, 74, 105
 - Replacing the inliner seal 71, 101

Replacing the locking screw seal 46, 76, 108
Replacing the PTFE inliner 73, 103
Replacing the seals for RSV-P 107
Replacing the slide blade . . 31, 47, 55, 77, 85, 108

S

Safety precautions to be taken during welding
work on pipes 27
Special dangers 14
Stresses 25
Switches 18, 21, 24

T

Technical data sheet 17, 20, 23
Test number 17, 20, 23
Test process after an explosion/fire 32, 56, 86
Tightening torques 26
Tool required 26
Torque of RSV-D/RSV-G and RSV-P 26

W

Wear monitoring 36, 61, 62, 91, 92

Z

Zone inside/outside 17, 20, 23